



Technical Support Line: (952) 985-5675 Email: Info@QA1.net

21730 Hanover Ave.
Lakeville, MN 55044
www.QA1.net

INSTALLATION INSTRUCTIONS

*'63-'86 Chevrolet C10/ GMC C15, C1500, '87-'91 Chevrolet/GMC R10, R1500 Front Coil-Over Conversion
QA1 P/N 52610-S650, 52610-S750, 52610-S850, 52610-D650, 52610-D750, 52610-D850
QA1 P/N 52611-S650, 52611-S750, 52611-S850, 52611-D650, 52611-D750, 52611-D850*

READ ALL INSTRUCTIONS CAREFULLY AND THOROUGHLY PRIOR TO STARTING INSTALLATION. PRODUCTS THAT HAVE BEEN INSTALLED ARE NOT ELIGIBLE FOR RETURN. USE THE PROPER JACKING LOCATIONS. DEATH OR SERIOUS INJURY CAN RESULT IF INSTRUCTIONS ARE NOT CORRECTLY FOLLOWED. A GOOD CHASSIS MANUAL, AVAILABLE AT YOUR LOCAL PARTS STORE, MAY ALSO AID IN YOUR INSTALLATION.

• DISCLAIMER / WARRANTY •

QA1 WARRANTS THAT THE PRODUCTS WILL BE FREE FROM DEFECTS IN MATERIAL AND WORKMANSHIP FOR ONE YEAR FROM DATE OF SALE TO THE ORIGINAL PURCHASER. QA1 MAKES NO OTHER WARRANTY OF ANY KIND, EXPRESS OR IMPLIED. QA1 SHALL HAVE NO OBLIGATION UNDER THE FOREGOING WARRANTY WHERE THE DEFECT IS THE RESULT OF IMPROPER OR ABNORMAL USE, YOUR NEGLIGENCE, VEHICLE ACCIDENT, IMPROPER OR INCORRECT INSTALLATION OR MAINTENANCE, NOR WHEN THE PRODUCT HAS BEEN REPAIRED OR ALTERED IN ANY WAY. QA1'S LIABILITY IN THE CASE OF DEFECTIVE PRODUCTS SUBJECT TO THE FOREGOING WARRANTY SHALL BE LIMITED TO THE REPAIR OR REPLACEMENT, AT QA1'S OPTION, OF THE DEFECTIVE PRODUCTS.

THE USER UNDERSTANDS AND RECOGNIZES THAT RACING PARTS, SPECIALIZED STREET ROD EQUIPMENT, AND ALL PARTS AND SERVICES SOLD BY QA1 ARE EXPOSED TO MANY AND VARIED CONDITIONS DUE TO THE MANNER IN WHICH THEY ARE INSTALLED AND USED. QA1 SHALL BEAR NO LIABILITY FOR ANY LOSS, DAMAGE OR INJURY, EITHER TO A PERSON OR TO PROPERTY, RESULTING FROM THE INSTALLATION, DIRECT OR INDIRECT USE OF ANY QA1 PRODUCTS OR INABILITY BY THE BUYER TO DETERMINE PROPER USE OR APPLICATION OF QA1 PRODUCTS. WITH THE EXCEPTION OF THE LIMITED LIABILITY WARRANTY SET FORTH ABOVE, QA1 SHALL NOT BE LIABLE FOR ANY CLAIMS, DEMANDS, INJURIES, DAMAGES, ACTIONS, OR CAUSES OF ACTION WHATSOEVER TO BUYER ARISING OUT OF OR CONNECTED WITH THE USE OF ANY QA1 PRODUCTS. MOTORSPORTS ARE DANGEROUS; AS SUCH, NO WARRANTY OR REPRESENTATION IS MADE AS TO THE PRODUCT'S ABILITY TO PROTECT THE USER FROM INJURY OR DEATH. THE USER ASSUMES THAT RISK!

TOOLS AND SUPPLIES REQUIRED

- Floor Jack
- Jack Stands
- SAE Wrench Set
- Ratchet & SAE Socket Set
- 1891-106 Ball Joint Tool Kit
- Torque Wrench
- Grinder or Air Chisel
- Drill & Drill Bit Set

Pre-Installation Note

QA1 C10 control arms are designed to use '73-'87 spindles. QA1 upper and lower control arms will work in conjunction with OE control arms with the correct ball joints, but the caster increase will only be about four degrees.

'71-'72 trucks can use '73 outer tie rod ends (Moog P/N ES409RT or equivalent) with the later spindles.

'63-'70 trucks will need to update the steering system to the '73 - later style or use QA1 adaptor tie rod sleeves, P/N 5256.

P/N 52601 lower control arms are designed to use QA1 front sway bar P/N 52896 and will not work with OE sway bars.

A complete exploded diagram is shown on page 6 and bill of materials on page 7.



Figure 1

Disassembly Instructions

1. Raise and support the vehicle by the frame rails with jack stands on a stable surface.
2. Remove the front wheels and brake calipers. For '73 and newer trucks, the brake hoses will need to be unbolted from the upper control arms. **Caution:** Do not allow the brake caliper to hang by the brake hose as this can damage the brake hose.
3. Unbolt the sway bar from the lower control arms if equipped.
4. Remove the shocks from the vehicle.
5. Remove the cotter pins from the ball joints and loosen the castle nuts. Do not remove the castle nuts at this time. Only loosen the castle nut on the control arms being replaced if both the upper and lower control arms are not being replaced.
6. Strike the flat surface on the spindle near the ball joint with a hammer to separate the ball joints from the spindle. A ball joint separating tool (pickle fork) may be required. See **Figure 1**.
7. Using a spring compressor, compress the front springs to take pressure off the lower control arm.
8. Place a floor jack under the lower control arm and remove the ball joint castle nuts. Lower the control arm out of the way. The spindle and spring can now be removed from the vehicle.
9. Remove the U-bolts retaining the lower control arm to the cross member and remove the lower control arms from the vehicle.
10. For '73-'91 models, the brake hose must be removed from the upper control arm before the control arms can be removed from the vehicle. The hose will need to be relocated to the cross member during reassembly if QA1 upper control arms are used.
11. Remove the nuts from the upper control arm cross shaft and remove the upper control arm and shims from the vehicle.
12. Using an air chisel or a grinder, remove the rivets holding the upper control arm mount to the top of the cross member. See **Figure 2**.
13. Remove the four bolts holding the upper control arm mount to the frame rail and discard. It may be easier to remove the passenger side exhaust header to access the bolts. See **Figure 3**.

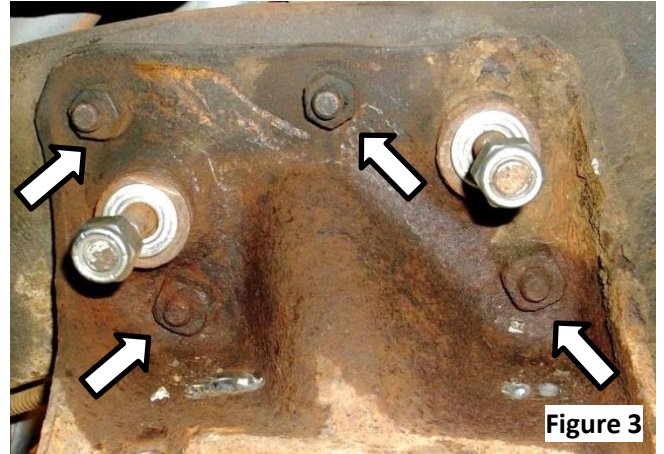
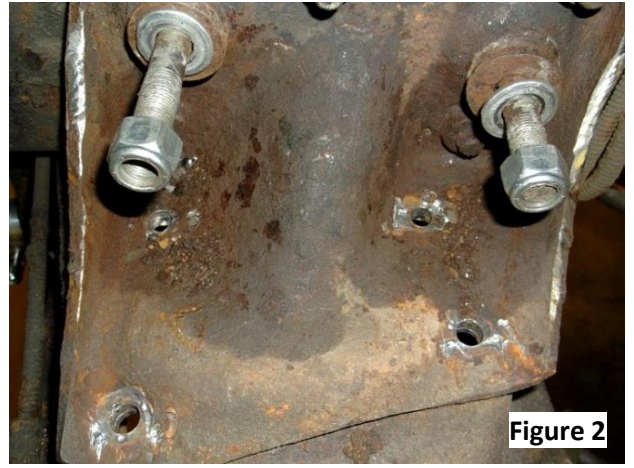

Installation Instructions

1. Set the QA1 upper control arm bracket in place and line up the mounting holes to use as a template. Mark the center opening on the cross member with a marker or scribe. **Note:** The brackets are right and left hand specific.
2. Remove the control arm bracket and begin cutting the opening to match the bracket opening. Along the cut line. **Note:** It is best to cut small and enlarge the opening as needed. See **Figure 4 and 5**.
3. After the cross member is cut and the bracket sits flat, loosely install all four 3/8" x 1 1/4" bolts, washers and nuts into the cross member and four 7/16" x 1 1/4" bolts, washers and nuts into the

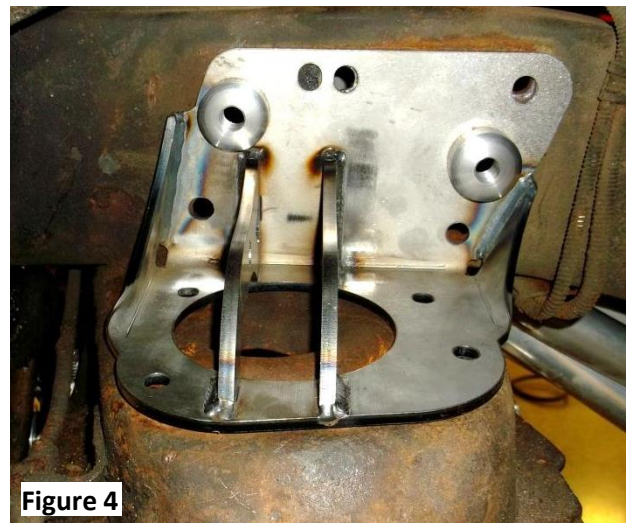

frame holes. Snug the frame bolts first followed by the cross member bolts, then torque the frame bolts followed by the cross member bolts. Torque the 3/8" bolts to 30 lb. ft. and the 7/16" bolts to 45 lb. ft.

Note: Minor variations have been found in the chassis and/or the frame can spring slightly when the factory upper control arm mount is removed. It may be necessary to pull the frame rails together slightly or run a 3/8" drill bit through the cross member bolt holes during installation of the QA1 mount.

4. Install the assembled shocks up through the spring pocket and install the 1/2" x 2 1/2" blots, washers and nuts. P/N 9033-430 spacer will need to be installed on each side of the spherical bearing as the shock is bolted into place. See **Figure 6**.

Installation Tip: The upper eyelet of the shock can be unscrewed from the piston rod and removed to install the spring and spring cap. Once reassembled, retighten the jam nut against the bottom of the loop.

5. Install the provided concave spacers, then the QA1 upper control arm or '63-'72 OE upper control arm with the flat side of the cross shaft towards the mount (**Figure 7**). Torque the nuts to 70 lb. ft. See **Figure 16** for control arm identification.

Note: For '73-'87 trucks using factory upper control arms, the factory convex spacers will not be reused with QA1 upper control arms, but should be reused with factory upper control arms in addition to the concave spacers provided. The '73-'87 convex spacers can be installed between the mount and the cross shaft (**Figure 8**) or if additional negative camber is needed the cross shaft can be flipped over and the convex spacers used under the mounting nut. See **Figure 9**.

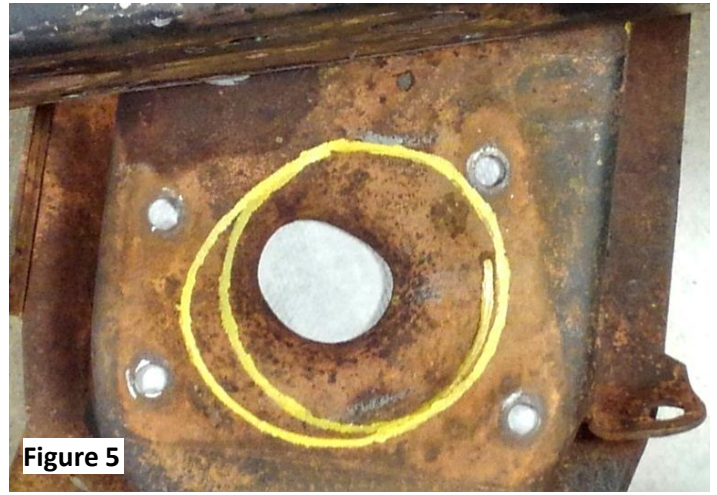

Figure 5

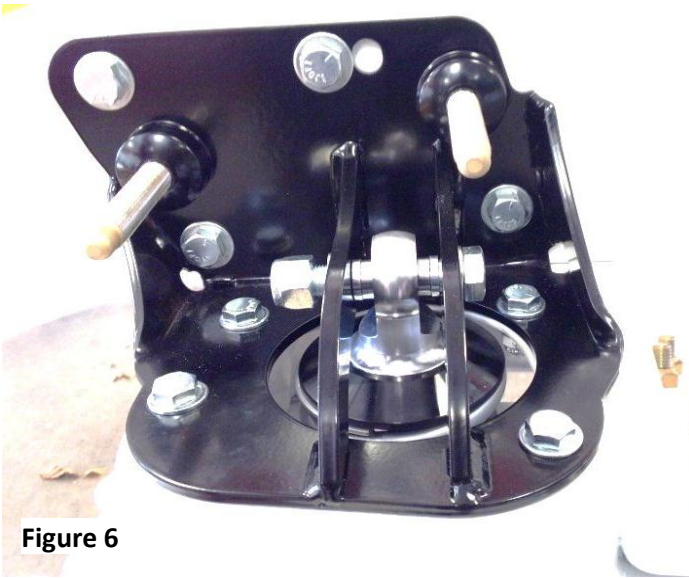

Figure 6



Figure 7



Figure 8



Figure 9

6. The lower control arm U-bolt holes on the cross member will need to be enlarged to 9/16" for '72 and earlier trucks to accept the supplied 9/16" U-bolts.

ITEM#	PART #	DESCRIPTION
1		LOWER C-O CONTROL ARM ASM.
8	9037-615 RH 9037-616 LH	BRACKET, STEERING STOP C-O
9	*	NUT, HEX 3/8-16
10	*	WASHER, FLAT 3/8" SAE
11	*	BOLT, HEX 3/8-16 X 1"
19	*9047-113	BUMP STOP, BULLET 1.5" OD X 1.56" TALL

*INCLUDED IN HARDWARE KIT 7039-215

7. Install the bump stop on the bump stop mount using a 3/8" nut and washer. Install the bump stop mount on the lower control arm with the supplied 3/8" x 1" bolts, washers and nuts. Torque to 30 lb. ft. **Figure 10.**

8. Bolt the lower shock mount brackets to the lower control arms using a 1/2" x 1 3/4" bolt, washers and nut near the ball joint and a 1/2" x 3" bolt, washers and nut towards the control arm pivot point. Spacer p/n 9033-101 will need to be installed between the mounting brackets near the pivot point. See **Figure 11.** Torque the bolts to 50 lb. ft.

9. Inspect the lower control arm mounts on the cross member for burrs or sharp edges that could dig into the cross shaft and clean up as necessary. See **Figure 12.**

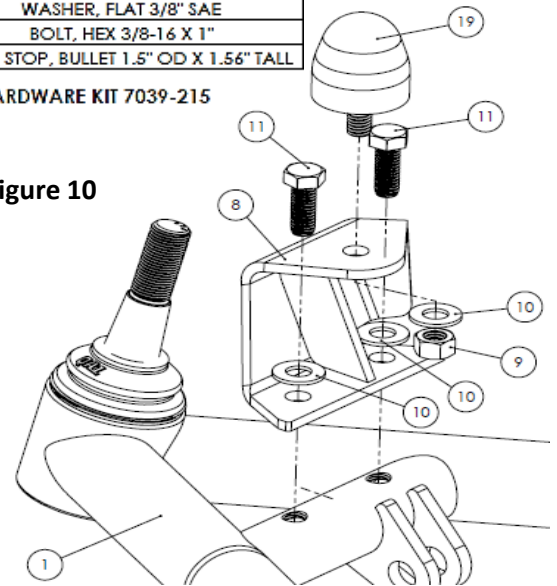

Figure 10



Figure 11

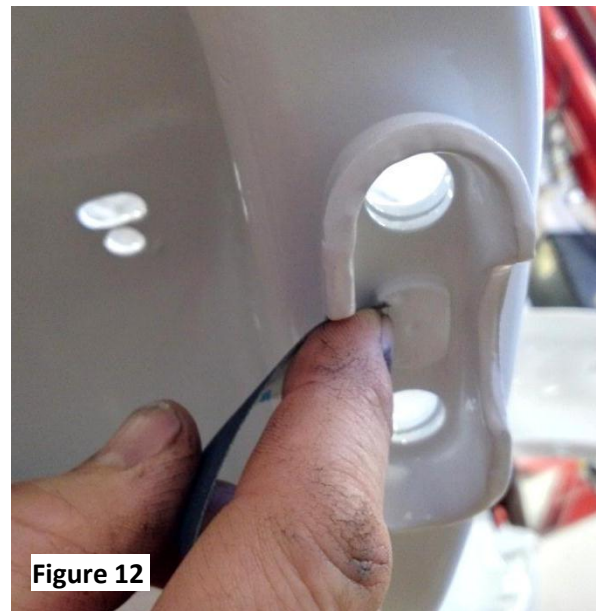

Figure 12

10. Install the QA1 lower control arm with the supplied U-bolts. The alignment dowel on the cross member must be seated into the cross shaft. Torque the nuts evenly to 70 lb. ft. See **Figure 10.**

11. Install the lower shock mount brackets on the lower shock eyelet using a 1/2" x 2 1/2" bolt, washers, 9033-430 spacers and 1/2" nuts like on the upper mount.

12. Install the spindle on the upper ball joint.

13. Raise the lower control arm up to the spindle and connect the lower ball joint.

14. Tighten the upper ball joint castle nuts to 50 lb. ft. and the lower ball joint castle nut to 90 lb. ft. Once torqued, tighten the nuts until the cotter pin is able to be installed. **Never loosen a castle nut to align cotter pin.**

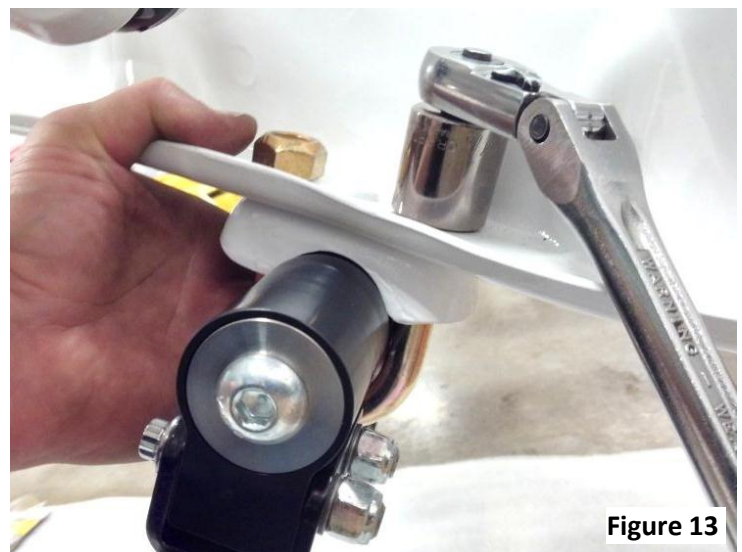

Figure 13

15. When using QA1 upper control arms, 1973 and later trucks will need the brake hose rerouted to the front side of the spring pocket on the cross member and attached there using the factory bolt and nut as shown in **Figure 14 & 15**.

- a. Drill a 3/8" hole just above the flange on the cross member.
- b. Insert the locating tab for the brake hose mount and mark the location for the bolt.
- c. Drill a 5/16" hole and mount the brake hose using the OE mounting bolt and nut.
- d. To help ensure the steering does not contact the brake hose, rotate the clamps and bolts for the tie rod adjusters towards the front of the truck. Bend the mounting bracket to reposition the hose as needed.

16. QA1 Sway bar P/N 52896 can now be installed. Refer to the instructions included with the sway bar for this step.

17. Reinstall the brake calipers and wheels.

18. Pump the brake pedal to seat the brake pads against the rotor. Bleed the brakes before driving if the brake hydraulic system has been opened.

Caution: QA1 does not recommend driving the vehicle until it has been properly aligned due to major changes in suspension geometry that will affect the handling characteristics of the vehicle. A front end alignment should be performed by a qualified alignment shop after any changes to the suspension system.



Alignment Information

These components are designed to add more caster and negative camber. It is a good idea to make the alignment shop aware of this, as the alignment shop may only try to align the vehicle to factory specs. These alignment specifications are for vehicles equipped with both QA1 upper and lower control arms. Vehicles with other configurations may not be able to achieve these alignment specifications.

Camber:	-0.5° ± 0.5°
Caster:	+8.0° ± 0.5°
Toe:	+0.2° ± 0.1°

Maintenance of QA1 Ultimate Ball Joints

Grease using high quality NLGI #2 GC-LB Lithium based grease and check preload on a regular basis. Check and set ball joint preload at least annually or every 3,000 miles, whichever comes first. NOTE: Preload on the ball stud can be set with the ball joint attached to the control arm if the spring is unloaded and the ball joint taper is free from the spindle.

1. Using the QA1 spanner socket from Ball Joint Tool Kit (p/n 1891-106) loosen the lock nut by turning counter clockwise.
2. Using the QA1 hex key, torque the torque nut to 25-30 in. lbs. and then back off 90°.
3. Using the QA1 hex key, a ½" open-ended wrench or socket, and the QA1 spanner wrench, tighten the lock nut while holding the torque nut, locking them together to 25 ft. lbs.
4. Re-check the lash on the ball stud and adjust as needed. The ball stud should not have any axial lash.

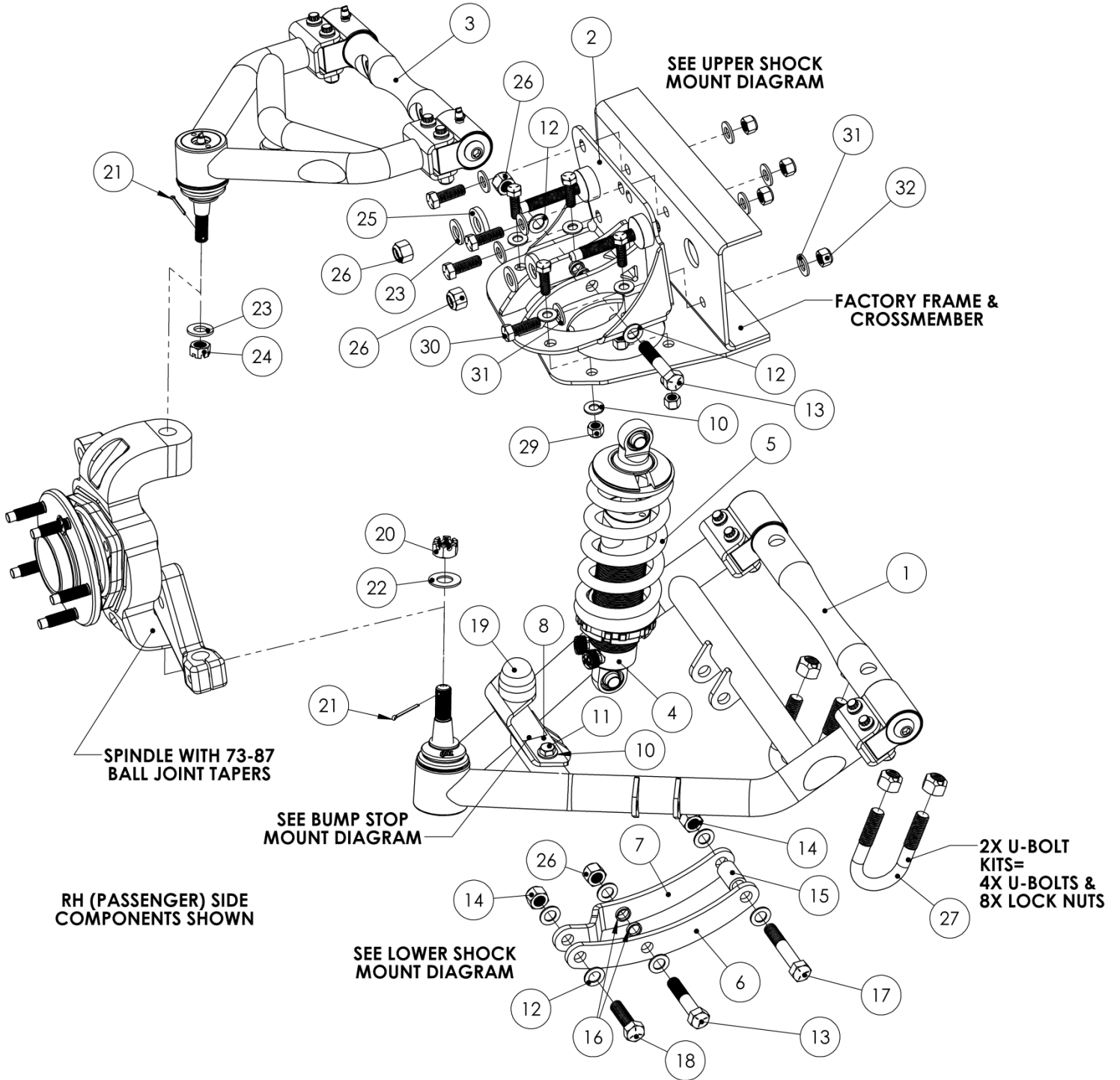

ITEM #	PART #	DESCRIPTION	QTY.
1	52610 LH & RH	LOWER C-O CONTROL ARM ASM.	2
2	9037-626 RH 9037-627 LH	MOUNT ASM., UPPER C-O SHOCK	2
3	52602 LH & RH	UPPER CONTROL ARM ASM.	2
4	DD401	SHOCK PROMA C-O D-ADJ 10.13	2
5	10HTXXX	SPRING, 10" HIGH TRAVEL 2-1/2" ID	2
6	9037-625	BRACKET, LOWER SHOCK MOUNT	2
7	9037-623 RH 9037-624 LH	BRACKET, LOWER SHOCK MOUNT	2
8	9037-615 RH 9037-616 LH	BRACKET, STEERING STOP C-O	2
9	*	NUT, HEX 3/8-16	2
10	*	WASHER, FLAT 3/8" SAE	22
11	*	BOLT, HEX 3/8-16 X 1"	4
12	*	WASHER, FLAT 1/2" AN960-816 CLEAR-ZINC	16
13	*	BOLT, HEX 1/2-20 X 2.5"	4
14	*	NUT, NYLOCK 1/2-13	4
15	*	SLEEVE, .500" ID X .75" OD X 1.25"	2
16	*	SLEEVE, .5" ID X .625" OD X .125"	8
17	*	BOLT, HEX 1/2-13 X 3.0"	2
18	*	BOLT, HEX 1/2-13 X 1.75"	2
19	*9047-113	BUMP STOP, BULLET 1.5" OD X 1.56" TALL	2
20	*	NUT, SLOTTED (CASTLE) 5/8-18	2
21	*	COTTER PIN 7/64" X 1.25"	4
22	*	WASHER, FLAT 5/8" SAE	2
23	**	WASHER, FLAT 1/2" SAE	6
24	**	NUT, SLOTTED (CASTLE) 1/2-20	2
25	*9005-287	WASHER, SPHERICAL .650" ID	4
26	*	1/2-20 NYLOCK NUT	8
27	9012-301	U-BOLT KIT, 9/16-12 X 1.625 X 3.25"	2
28	*	BOLT, HEX 3/8-16 X 1.25"	8
29	*	NUT, NYLOCK 3/8-16	8
30	*	BOLT, HEX 7/16-14 X 1.25"	8
31	*	WASHER, FLAT 7/16" SAE	16
32	*	NUT, NYLOCK 7/16-14	8

*INCLUDED IN HARDWARE KIT 7039-215
** INCLUDED IN HARDWARE KIT 7038-218

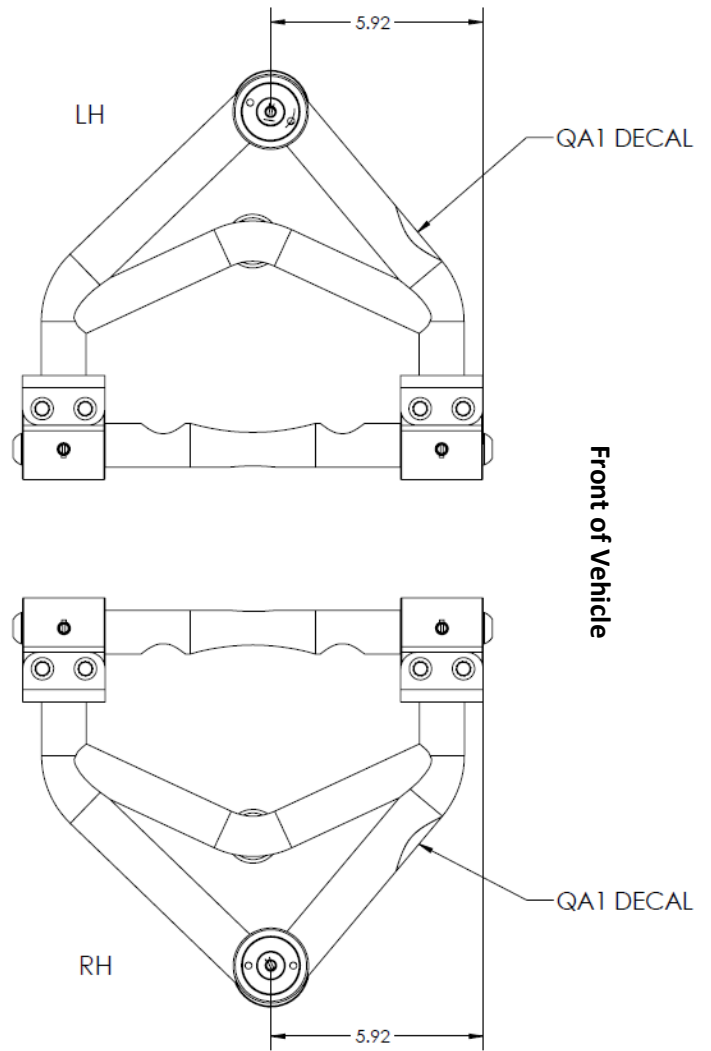

Figure 16; Upper Control Arms

Dedicated Technical Support Team

QA1 is dedicated to providing quality support and instructions. We employ passionate racers and car enthusiasts that know our products and the industry to better serve you.

Give our tech support line a call at **1.800.721.7761**

Visit online at www.QA1.net/tech or www.YouTube.com/QA1Tech for:

- Frequently Asked Questions
- Quick Tips
- Install Information
- Tuning and Repair Guides
- Other Technical Information

Our technical support and order lines are open **Monday – Friday, 8 am to 5 pm CST.**

