



**DON'T FORGET**

These instructions can be found in color and expandable at QA1.net

### INSTALLATION INSTRUCTIONS

QA1 P/N 52863 Rear Sway bar for QA1 Suspension System  
'73-'79 Ford F100

### TOOLS AND SUPPLIES REQUIRED

- Floor Jack
- Jack Stands
- SAE Wrench Set
- SAE Ratchet & Socket Set

**NOTE: The Shock mounts on the factory axle will need to be removed to install this sway bar.**

**This sway bar is designed to be used with QA1 rear coil-over suspension and will not work with stock suspension.**

1. Jack the rear of the truck up and securely place on jack stands.

2. The driver and passenger side inner frame brackets should be installed during the rear suspension installation with 7/16" hardware. The passenger side bracket that mounts the swedged tube of the watts link will be the shared connection with the sway bar end link. The driver side inner frame bracket is where the driver side sway bar end link will attach. **(Figure 1)**

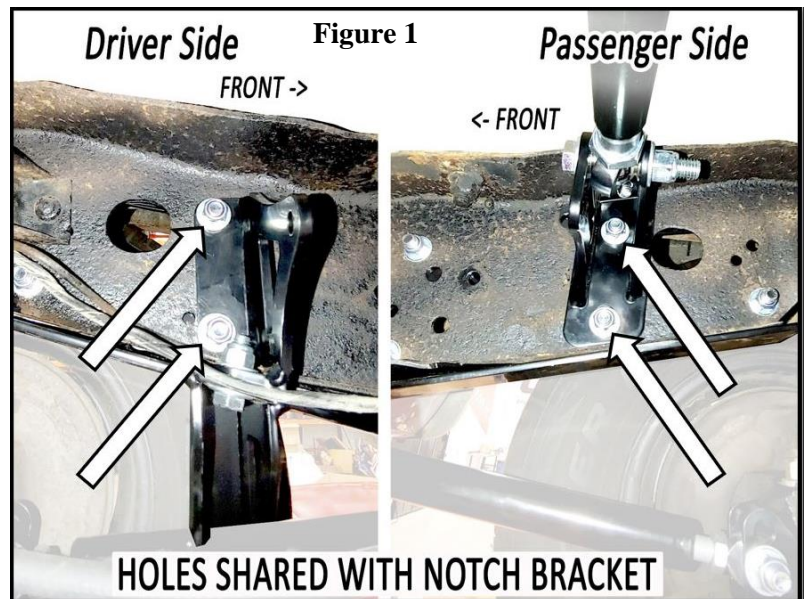

3. Install the bushings and chassis mounts onto sway bar. **(Figure 2)**

4. Mount the sway bar chassis mounts to the axle using the included axle u-bolts, 1/2" washers, and 1/2" nuts. Evenly space the sway bar to the frame mounts. Torque to 50 lb. ft. **(Figure 3 & 4)**



**Figure 2**



**Figure 3**

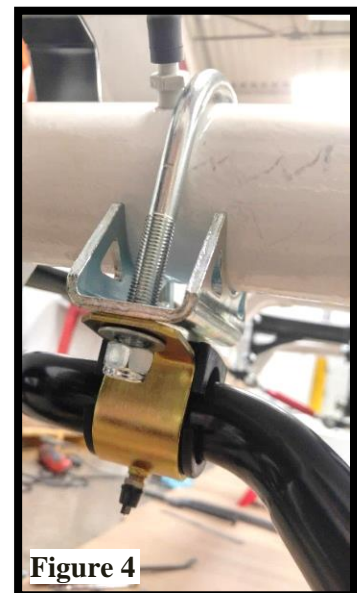

**Figure 4**

**INSTALL NOTE:**

The brake line junction on the axle may need to be spaced off the axle as to not interfere with driver side axle u-bolt. (Figure 5)

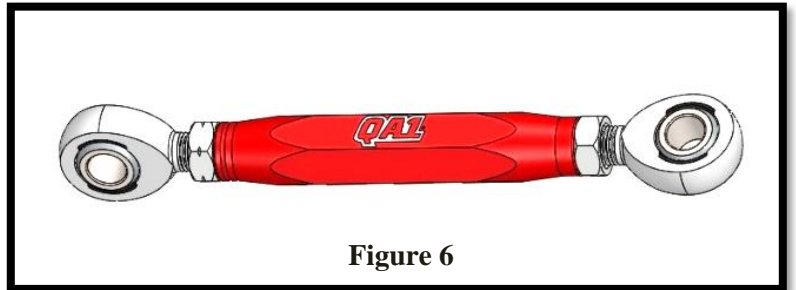
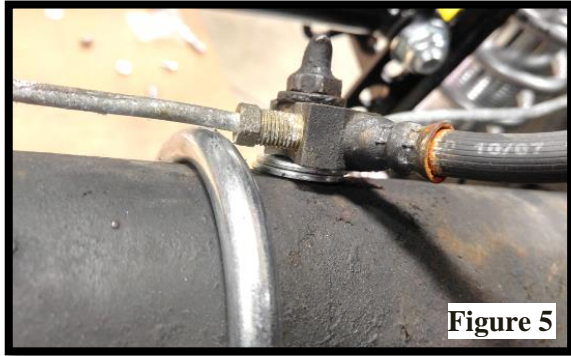

5. Install the 1/2" right-hand thread jam nuts onto the right-hand threaded rod ends. Each red adjuster sleeve will have one left-hand threaded side and one right-hand threaded side with matching rod ends/jam nuts. Using anti-seize on the rod end threads, thread the rod end into the anodized red adjustment sleeve. Do the same on the left-hand threaded side of the adjuster sleeve with the left-hand threaded jam nut on the left-hand threaded rod end. Thread the rod ends all the way into the adjustment sleeve. (Figure 6)
6. Attach one assembled adjustment rod to the **REAR** of the driver side inner frame bracket using two high misalignment spacers installed into the bore of the rod end. (Figure 7) Fasten to the frame mount using 3/8" x 2.5" bolts, with one washer on the nylock nut side of the bolt. Torque to 31 lb. ft.
7. Attach the passenger side end link to the **FRONT** of the frame bracket using two high misalignment spacers installed into the bore of the rod end. (Figure 7) Fasten bracket connections using 3/8" x 2.5" bolts, with one washer on the nyloc nut side of the bolt. Torque to 31 lb. ft.

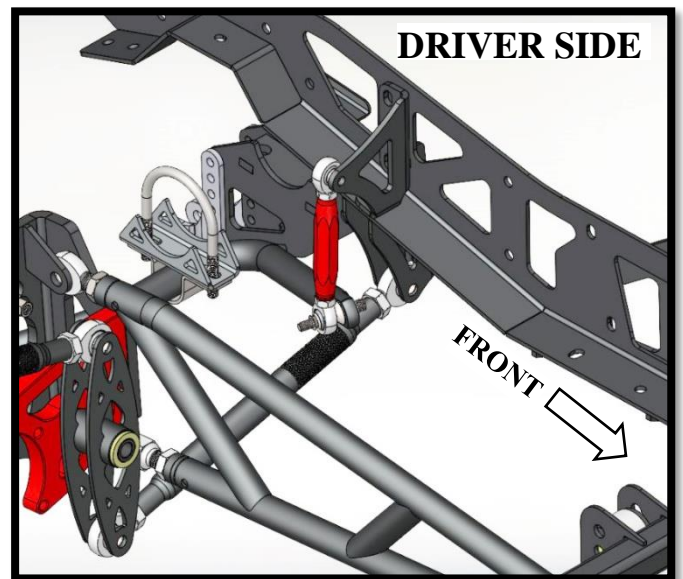
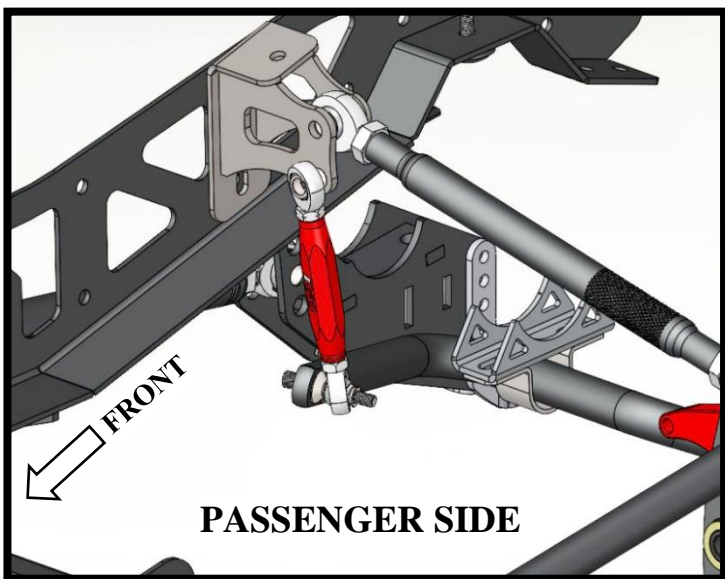
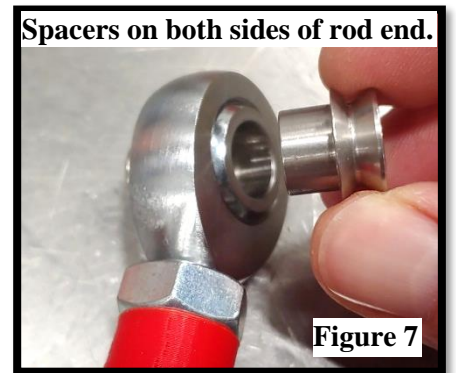



8. Attach the sway bar to the adjuster link using the specialty high misalignment stud with 1/2" washer and nylock nut on the sway bar side. **(Figure 8)** Attach the end link side using one high misalignment spacer and a 3/8" nylock nut. Torque connection to 31 lb. ft.
9. At ride height, adjust the end links so that the sway bar "legs" are parallel with the ground. Tighten the jam nuts to complete the install.
10. Grease the zerk fittings with 2-3 pumps of marine grease for bushing connections.

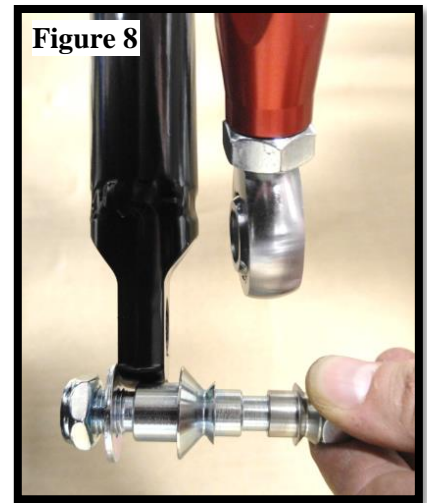

Technical Support Line: (952) 985-5675 Email: sales@QA1.net

READ ALL INSTRUCTIONS CAREFULLY AND THOROUGHLY PRIOR TO STARTING INSTALLATION. PRODUCTS THAT HAVE BEEN INSTALLED ARE NOT ELIGIBLE FOR RETURN. USE THE PROPER JACKING LOCATIONS. DEATH OR SERIOUS INJURY CAN RESULT IF INSTRUCTIONS ARE NOT CORRECTLY FOLLOWED. A GOOD CHASSIS MANUAL, AVAILABLE AT YOUR LOCAL PARTS STORE, MAY ALSO AID IN YOUR INSTALLATION.

• **DISCLAIMER / WARRANTY** •

QA1 WARRANTS THAT THE PRODUCTS WILL BE FREE FROM DEFECTS IN MATERIAL AND WORKMANSHIP FOR ONE YEAR FROM DATE OF SALE TO THE ORIGINAL PURCHASER. QA1 MAKES NO OTHER WARRANTY OF ANY KIND, EXPRESS OR IMPLIED. QA1 SHALL HAVE NO OBLIGATION UNDER THE FOREGOING WARRANTY WHERE THE DEFECT IS THE RESULT OF IMPROPER OR ABNORMAL USE, YOUR NEGLIGENCE, VEHICLE ACCIDENT, IMPROPER OR INCORRECT INSTALLATION OR MAINTENANCE, NOR WHEN THE PRODUCT HAS BEEN REPAIRED OR ALTERED IN ANY WAY. QA1'S LIABILITY IN THE CASE OF DEFECTIVE PRODUCTS SUBJECT TO THE FOREGOING WARRANTY SHALL BE LIMITED TO THE REPAIR OR REPLACEMENT, AT QA1'S OPTION, OF THE DEFECTIVE PRODUCTS.

THE USER UNDERSTANDS AND RECOGNIZES THAT RACING PARTS, SPECIALIZED STREET ROD EQUIPMENT, AND ALL PARTS AND SERVICES SOLD BY QA1 ARE EXPOSED TO MANY AND VARIED CONDITIONS DUE TO THE MANNER IN WHICH THEY ARE INSTALLED AND USED. QA1 SHALL BEAR NO LIABILITY FOR ANY LOSS, DAMAGE OR INJURY, EITHER TO A PERSON OR TO PROPERTY, RESULTING FROM THE INSTALLATION, DIRECT OR INDIRECT USE OF ANY QA1 PRODUCTS OR INABILITY BY THE BUYER TO DETERMINE PROPER USE OR APPLICATION OF QA1 PRODUCTS. WITH THE EXCEPTION OF THE LIMITED LIABILITY WARRANTY SET FORTH ABOVE, QA1 SHALL NOT BE LIABLE FOR ANY CLAIMS, DEMANDS, INJURIES, DAMAGES, ACTIONS, OR CAUSES OF ACTION WHATSOEVER TO BUYER ARISING OUT OF OR CONNECTED WITH THE USE OF ANY QA1 PRODUCTS. MOTORSPORTS ARE DANGEROUS; AS SUCH, NO WARRANTY OR REPRESENTATION IS MADE AS TO THE PRODUCT'S ABILITY TO PROTECT THE USER FROM INJURY OR DEATH. THE USER ASSUMES THAT RISK!

# DEDICATED TECH SUPPORT

QA1 is dedicated to providing quality support and instructions. We employ passionate racers and car enthusiasts that know our products and the industry to better serve you.

*CHECK US OUT ON YOUTUBE!*

- Frequently Asked Questions
- Quick Tips
- Install Information
- Tuning and Repair Guides
- Other Technical Information

[linkedin.com/company/qa1](https://www.linkedin.com/company/qa1)

[instagram.com/qa1motorsports](https://www.instagram.com/qa1motorsports)

[facebook.com/qa1motorsports](https://www.facebook.com/qa1motorsports)

[www.qa1.net/tech](http://www.qa1.net/tech)