



Equipped with AEM® Dryflow™ Filter
No Oil Required!

INSTALLATION INSTRUCTIONS

PART NUMBER

21-732C (Gun Metal Grey Finish)

2015	Subaru	WRX	2.0L H4 Turbo	C.A.R.B E.O # D-670-22
2016	Subaru	WRX	2.0L H4 Turbo	

ITEM NO.	PART NUMBER	DESCRIPTION	QTY.
1	20-8537B	HEAT SHIELD, 2015 SUBARU WRX	1
2	2-1476C	TUBE; 2015 SUBARU WRX, 21-732	1
3	21-2027DK	AIR FILTER; 2.75" X 7" DRYFLOW	1
4	1228596	MOUNT, RUBBER M6 X 3/4" TALL M/F	1
5	08160	WASHER; 1"D X 1/4 HOLE FENDER	1
6	444.460.04	NUT, M6 HEX SERRATED	1
7	1-2051	BOLT, BTN HD M4-0.7 X 6MM	2
8	102496	EDGE TRIM; 3/4" BULB, TOP LOC, 39"L	1
9	8-197-1	EXTENSION HARNESS; 5 PIN 18" DENSO	1
10	22224	BOLT; M6X1.00X12 HEX; FLG, GRADE 10.9, GEO	1
11	1-3025	WASHER, M6 SPLIT LOCK ZINC	1
12	9448	1/2" BNDHOSE CLAMP,2.56"-3.50"	1

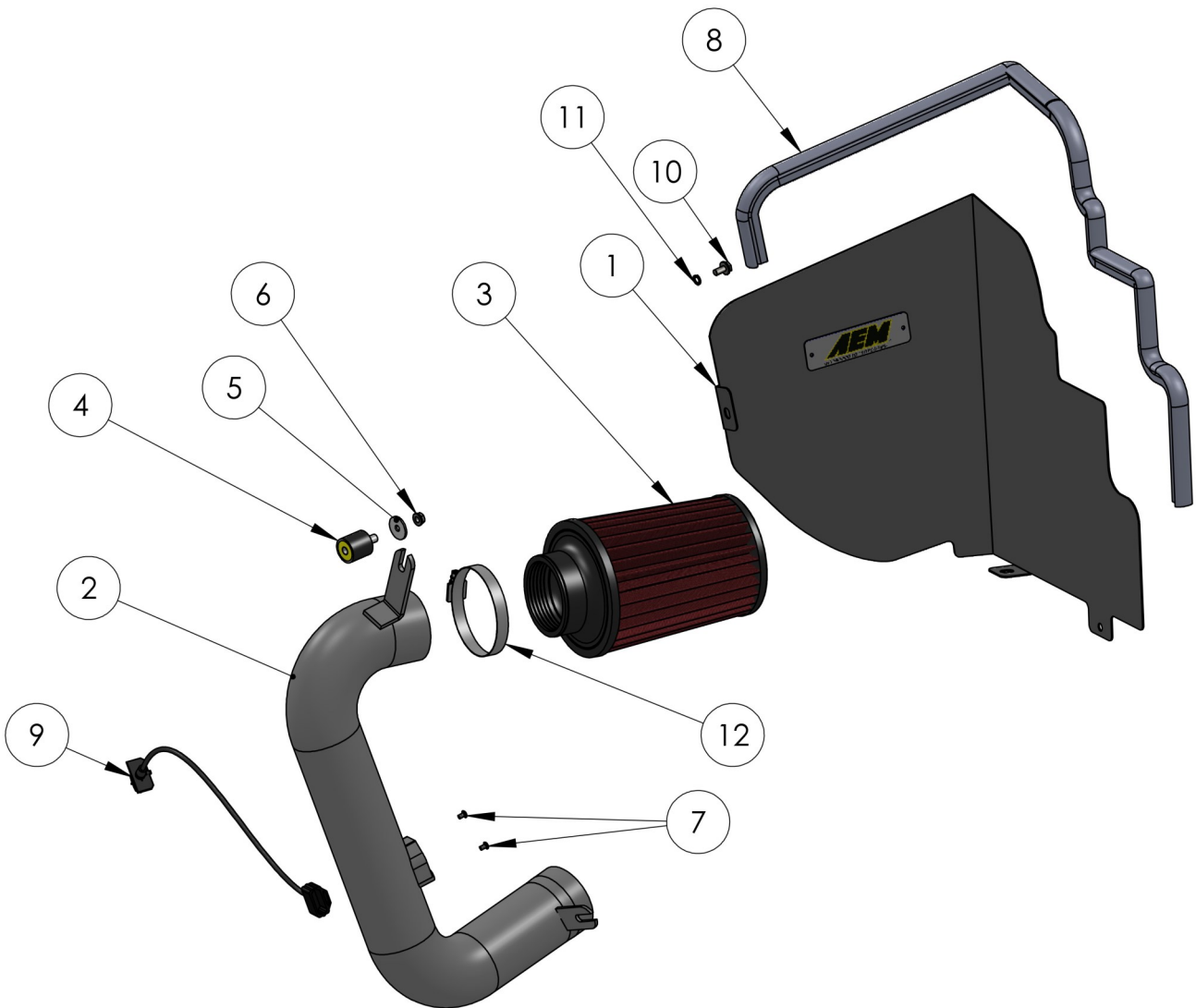

Read and understand these instructions **BEFORE** attempting to install this product. Failure to follow installation instructions and not using the provided hardware may damage the intake tube, throttle body and engine.

1. Preparing Vehicle

- a. Make sure vehicle is parked on level surface.
- b. Set the parking brake.
- c. If engine has run in the past two hours, let it cool down.
- d. Disconnect negative battery terminal.
- e. Do not discard stock components after removal of the factory system.
- f. Open the air intake kit package and make sure all parts are included.

Tools Needed:

Screw driver
10MM socket
Socket Driver
Side Cutters
4MM Hex Key

2. Removal of stock system

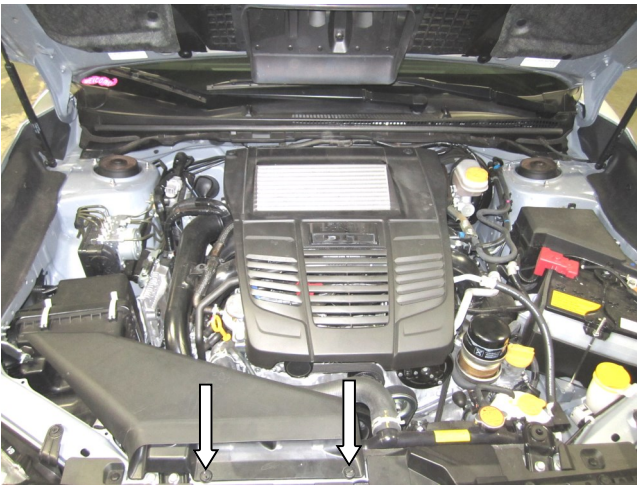

a. Remove the two plastic clips and the factory fresh air inlet duct.



b. Depress the tab on the mass air flow sensor plug and disconnect it from the MAF sensor.



c. Remove the two nuts on the fender that secure the bracket for the air box.



d. Remove the bolt that secures the air box to the engine bay and set aside for late use with AEM heat shield.



e. Unlatch and carefully remove the stock air box lid and filter from the engine bay.

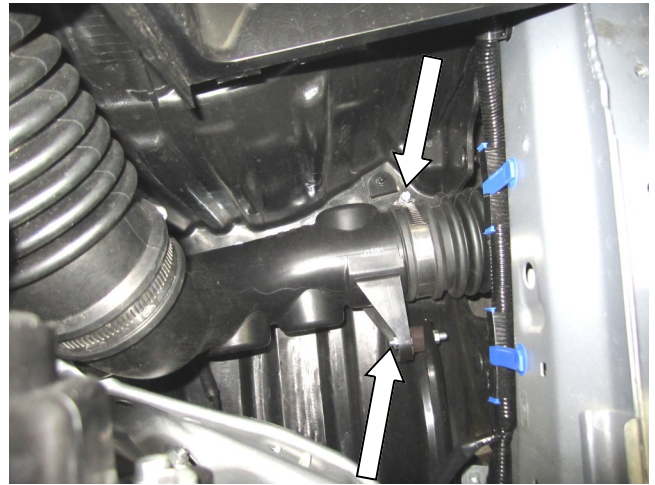

f. Loosen the hose clamp and M6 nut shown. Set stock nut aside for use later with AEM intake tube.



g. Slide the intake tube off the lower bellow coupler and remove tube/box assembly from engine bay.



h. Remove MAF sensor from stock air box and set aside for installation on AEM intake tube.

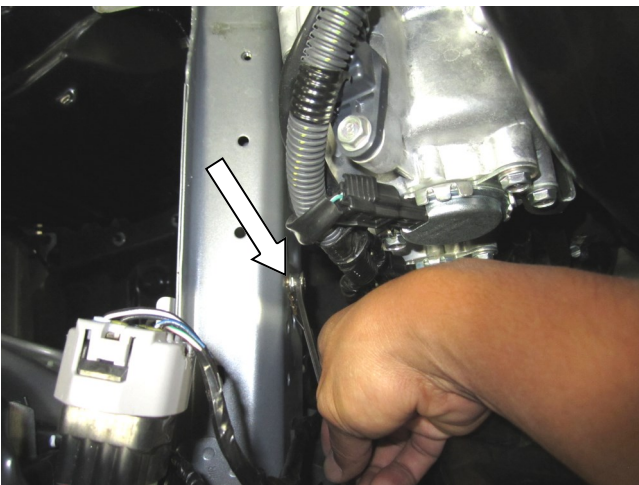

i. Remove the M6 ground bolt located on the lower frame rail and set aside for use with AEM heat shield.

3. Installation of AEM® intake system.

- a. When installing the intake system, do not completely tighten the hose clamps or mounting hardware until instructed to do so.



a. Install the mass air flow sensor that was removed in 2h) into the AEM intake tube with the supplied hardware (1-2051) using 4MM Hex Key.



b. Install the supplied edge trim(102496) onto the outer part of the heat shield leaving a 1 inch gap near the left mounting tab. Cut excess edge trim if necessary.



c. Install heat shield(20-8537) as shown, careful to avoid snagging high beam headlight harness.



d. Install the M6 bolt from 2i) onto the lower heat shield along with the ground wire back as shown.

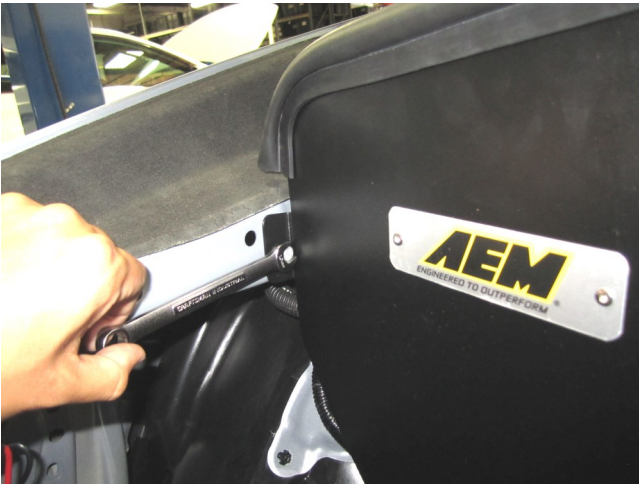

e. Use M6 bolt(22224) and crush washer(1-3025) to secure mounting tab to frame.



f. Use previously removed M6 bolt from 2d) to secure lower mounting tab on heat shield to frame as shown.



g. Install the provided rubber mount(1228596) as shown .

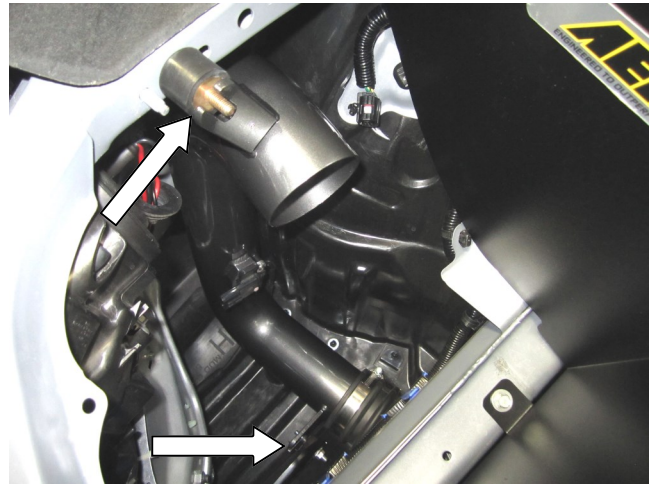

h. Insert AEM tube into lower bellow coupler and align mounting brackets as shown.



i. Connect the MAF extension harness(8-197-1) to the stock harness, around the tube, and plug into the MAF sensor.

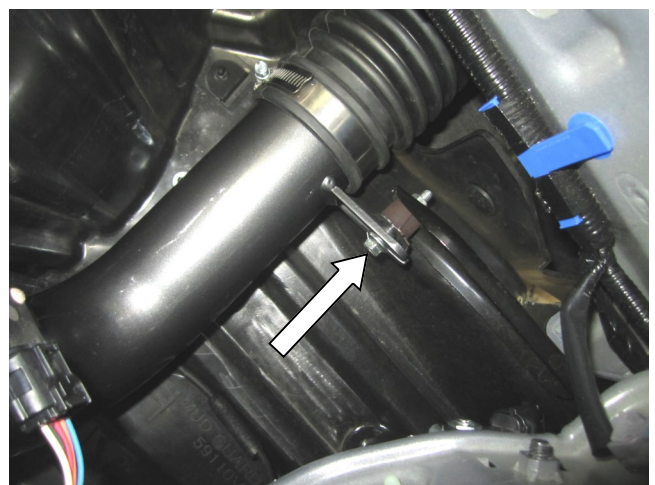

j. Use the stock nut from removal step 2f) to secure the lower intake bracket.



k. Use supplied nut(444.460.04) and washer(08160) to secure upper tube bracket to rubber mount.

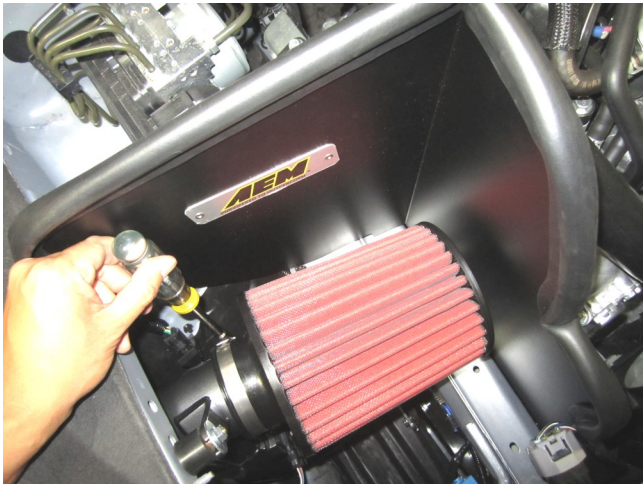

l. Install AEM DryFlow filter(21-2027DK) and secure to intake tube using hose clamp(9448) .

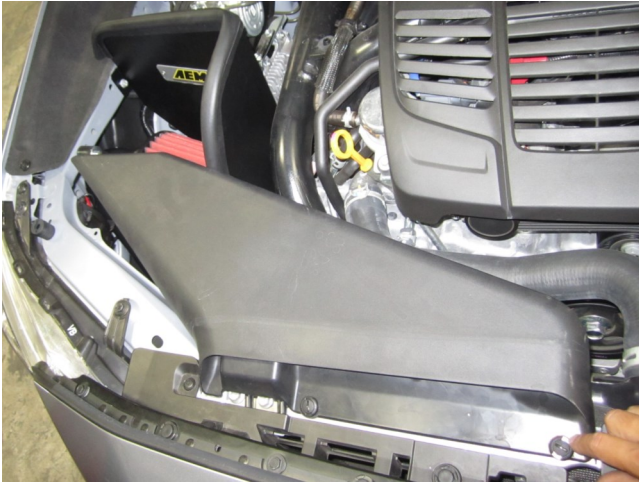

m. Reinstall stock air duct and plastic mounting clips. Ensure clearance with filter and adjust position of tube if necessary.



n. AEM intake installed.

4. Reassemble Vehicle

- a. Position the inlet pipes for the best fitment. Be sure that the pipes or any other components do not contact any part of the vehicle.
- b. Check for proper hood clearance. Re-adjust pipes if necessary and re-tighten them.
- c. Inspect the engine bay for any loose tools and check that all fasteners that were moved or removed are properly tightened.
- d. Reconnect negative battery terminal and start engine. Let the vehicle idle for 3 minutes. Perform a final inspection before driving the vehicle.

5. Service and Maintenance

- a. AEM Induction Systems requires cleaning the intake system's air filter element every 100,000 miles. When used in dusty or off-road environments, our filters will require cleaning more often. We recommend that you visually inspect your filter once every 25,000 miles to determine if the screen is still visible. When the screen is no longer visible some place on the filter element, it is time to clean it. To clean, purchase our Synthetic air filter cleaner, part number 1-1000 and follow the easy instructions.
- b. Use window cleaner to clean your powder coated AEM[®] intake tube.

NOTE: DO NOT USE aluminum polish on powder coated AEM[®] intake tubes.

For technical inquiries
e-mail us at
sales@aemintakes.com
or
call us at
800.992.3000

AEM Air Intake System Warranty Policy

AEM® warrants that its intake systems will last for the life of your vehicle. AEM® will not honor this warranty due to mechanical damage (i.e. improper installation or fitment), damage from misuse, accidents or flying debris. AEM® will not warrant its powder coating if the finish has been cleaned with a hydrocarbon-based solvent. The powder coating should only be cleaned with a mild soap and water solution. Proof of purchase of both the vehicle and AEM® intake system is required for redemption of a warranty claim.

This warranty is limited to the repair or replacement of the AEM® part. In no event shall this warranty exceed the original purchase price of the AEM® part nor shall AEM® be responsible for special, incidental or consequential damages or cost incurred due to the failure of this product. Warranty claims to AEM® must be transportation prepaid and accompanied with dated proof of purchase. This warranty applies only to the original purchaser of product and is nontransferable. Improper use or installation, use for racing, accident, abuse, unauthorized repairs or alterations voids this warranty. AEM® disclaims any liability for consequential damages due to breach of any written or implied warranty on all products manufactured by AEM®. Warranty returns will only be accepted by AEM® when accompanied by a valid Return Merchandise Authorization (RMA) number. Credit for defective products will be issued pending inspection. Product must be received by AEM® within 30 days of the date RMA is issued.

If you have a warranty issue, please call (800) 992-3000 and our customer service department will assist you. A proof of purchase is required for all AEM® warranty claims.