



Equipped with AEM® Dryflow™ Filter
No Oil Required!

INSTALLATION INSTRUCTIONS

PART NUMBER:21-8115

2002-2003	FORD	F350 Super Duty	V10-6.8L	SEE * NOTE
2000-2003	FORD	Excursion	V10-6.8L	SEE * NOTE
1999-2003	FORD	F250 Super Duty	V10-6.8L	SEE * NOTE
1999-2003	FORD	F550 Super Duty	V10-6.8L	SEE * NOTE
1999-2003	FORD	F450 Super Duty	V10-6.8L	SEE * NOTE
1999-2001	FORD	F350 Super Duty	V10-6.8L	C.A.R.B. E.O. # D-670

*** NOTE: Legal in California only for racing vehicles which may never be used upon a highway**

PARTS LIST

Description	Qty.	Part Number
A	1	21-2109DK
B	2	9452
C	1	20-8115
D	1	2-81152
E	1	5-324
F	2	9464
G	1	2-81151
H	1	5-454
I	1	103-BLO-7220N
J	1	35-3103
K	1	8-3020
L	1	8-4016
M	2	1-113
N	1	4093-4
O	1	8-129
P	2	4093-6
Q	1	784634
R	1	69801
S	1	1228560
T	2	8-352
U	2	8-353
V	1	8-311
W	1	5-7015
X	2	559960
Y	2	444.460.08

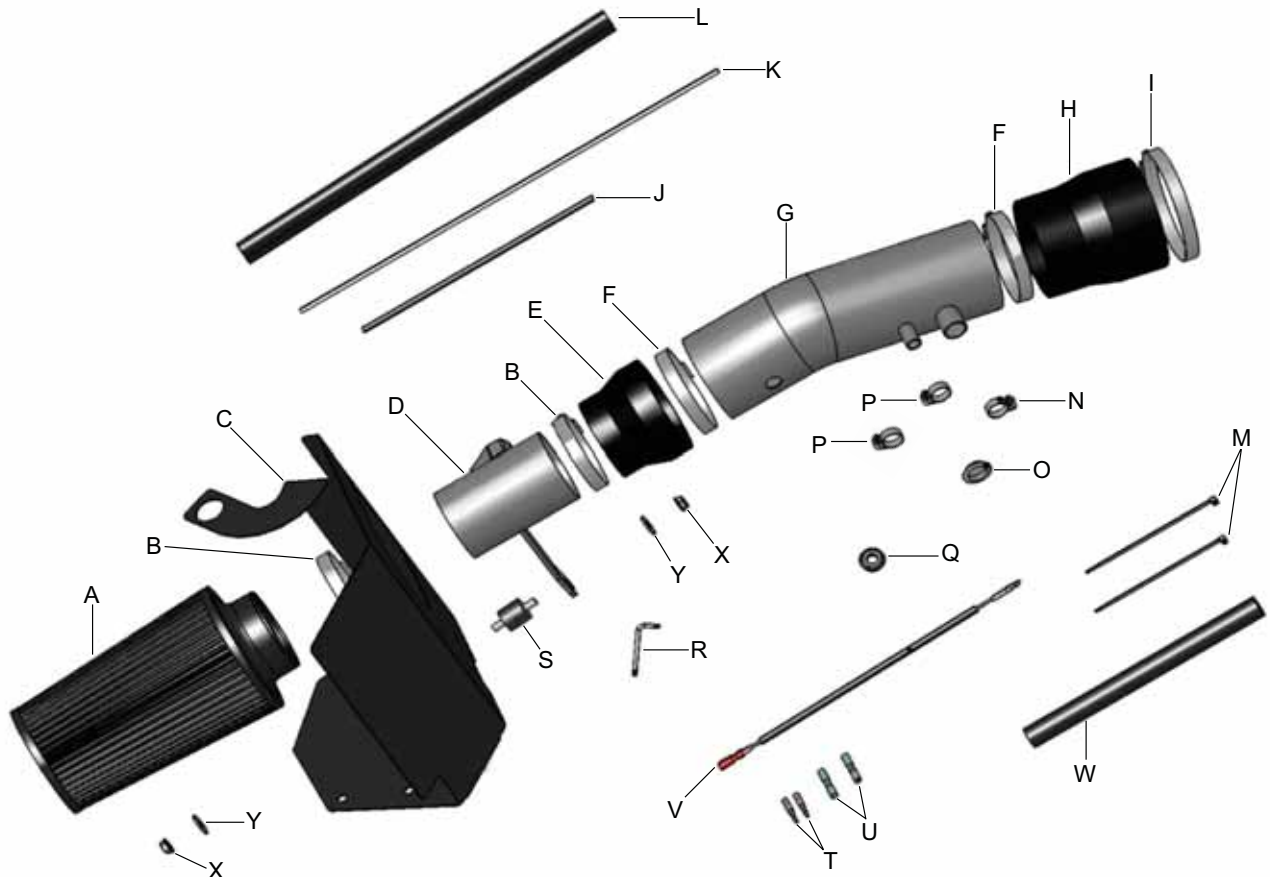

Read and understand these instructions **BEFORE** attempting to install this product. Failure to follow installation instructions and not using the provided hardware may damage the intake tube, throttle body and engine.

1. Preparing Vehicle

- a. Make sure vehicle is parked on level surface.
- b. Set parking brake.
- c. If engine has run in the past two hours, let it cool down.
- d. Disconnect negative battery terminal.
- e. Do not discard stock components after removal of the factory system.

2. Removal of stock system



a. Factory air box system installed.



b. Remove the jack hardware from the front of the engine bay.



c. Remove the two bolts securing the radiator support bracket located on the driver side of the engine bay. Remove the radiator support bracket.



d. Remove the two stock breather hoses from the upper intake tube. Loosen the hose clamp securing the upper intake tube to the throttle body.



e. Loosen the hose clamp attaching the intake tube to the air cleaner casing.



f. **NOTE: If you have a 2001-2003 Ford V10 proceed to step 2g.**
This step is only for 1999-2000 Ford V10's; unplug the inlet air temperature sensor located in the intake tube.



g. Remove the upper intake pipe from the engine bay.



h. Unclasp the clamp holding the two parts of the air filter box together.



i. Use a screwdriver to remove the mass air flow sensor from the inside of the air filter box.



j. After prying the plastic cover away from the air box. Disconnect the MAF wiring harness from the MAF.



k. Pull out the MAF wiring harness out of the air filter box.



l. Finally remove the lower part of the intake box by removing the three bolts holding it in place.

3. Inlet Air Temperature Wiring Extension (Only for Trucks with an external IAT)



a. Cut the two wires connecting the IAT connector to the vehicle as shown 4 inches from the connector. Strip 1/4" off all four wire ends.



b. Crimp the supplied female bullet terminal to each of the two wires. Heat the pink part of the connector with a heat gun.



c. This is how the connectors on the vehicle should look.



d. Crimp each of the supplied male bullet terminal connector to the IAT harness wires. Heat the pink part with a heat gun.



e. The IAT wiring harness should look like this when you are done. Then, connect it to the supplied wiring harness.

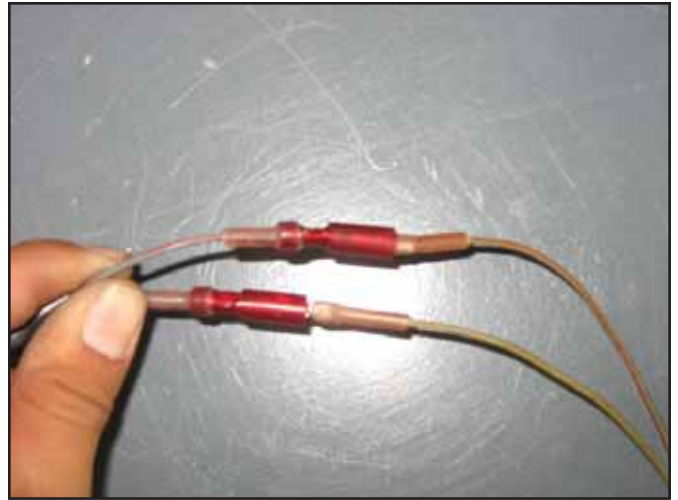

f. The two wires with red stripes should be connected. And, the other two plain wires should be connected.



g. This is how your new extended IAT wiring harness should look.



h. Connect the harness shown in step 3h to the wires prepped in step 3d. Be sure to color code the wires as you did in step 3g.



i. Wrap the connected extended wiring harness with the supplied fiber braid sheathing. Secure with black electrical tape.

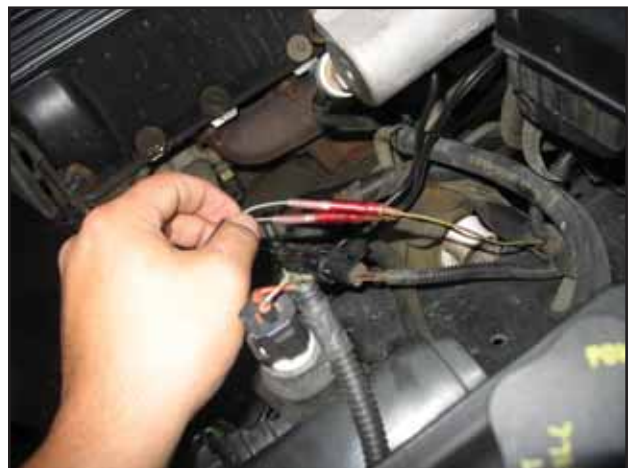

j. The fiber braid sheathing should extend to the plastic wire protectors.

4. Installation of AEM® intake system.

a. When installing the intake system, do not completely tighten the hose clamps or mounting hardware until instructed to do so.



b. Prepare the heatshield by lining it with the supplied sponge rubber gasket and rubber edge trim.

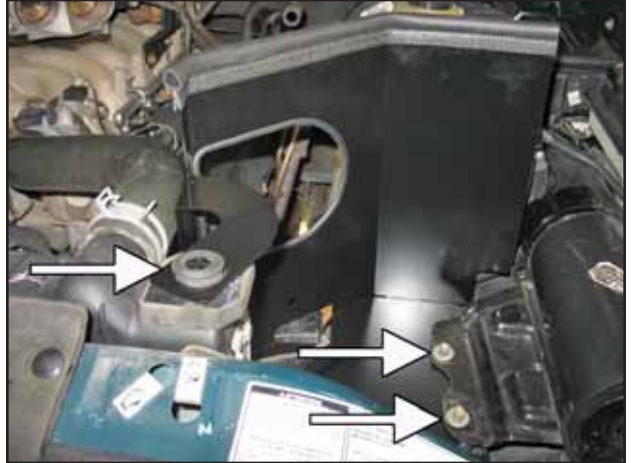

c. Slide the heatshield beneath the bracket holding the canister on the driver side of the truck, then line up the two holes. Line up the bigger hole on the top of the heatshield with the rubber grommet on the radiator.



d. Replace the the bracket removed in step 2c. over the heatshield tab locted over the stock radiator grommet.



e. Secure with the stock bolts.



f. Install the stock jack hardware removed in step 2b.



g. Insert the rubber mount in the hole on the heatshield and secure with supplied washer and nut.



h. Install the MAF sensor in the lower pipe securing it with the stock screws.



i. If no external IAT is present, plug the hole in the upper pipe with the provided plug, part # 8-129. If an external IAT is not present proceed to step 3k.



j. First install the supplied grommet in the hole located in the upper pipe. Then, carefully install the IAT sensor in the grommet.



k. Secure the supplied hose to the valve cover nipple using the supplied hose clamp. This hose is replacing the PCV hose.



l. Install the large reducing coupler at the throttle body, and loosely secure with the supplied #72 hose clamp.



m. Insert the upper intake pipe into the previously installed coupler and loosely secure using the supplied #64 hose clamp.



n. Install the smaller reducing coupler on the end of the upper intake pipe and loosely secure with the #64 hose clamp.



o. Secure, both breather hoses to the upper intake pipe using the supplied hose clamps.



p. Install the lower pipe into the coupler lining it up the bracket with the previously installed rubber mount. After alignment is complete, loosely secure the bracket to the rubber mount with the supplied washer and nut.



q. Re-connect the MAF sensor wiring harness to the MAF sensor installed in the lower pipe.



r. On vehicles with an IAT sensor, re-connect the IAT wiring harness to the sensor.



s. Finally, secure your Dryflow™ air filter to the end of the lower pipe with the supplied hose clamp.



Factory air box system installed



AEM® intake sytem installed

5. Reassemble Vehicle

- a. Position the inlet pipes for the best fitment. Be sure that the pipes or any other components do not contact any part of the vehicle. Tighten the rubber mount, all bolts, and hose clamps.
- b. Check for proper hood clearance. Re-adjust pipes if necessary and re-tighten them.
- c. Inspect the engine bay for any loose tools and check that all fasteners that were moved or removed are properly tightened.
- d. Reconnect negative battery terminals and start engine. Let the vehicle idle for 3 minutes. Perform a final inspection before driving the vehicle.

6. CARB Sticker Placement

- a. The C.A.R.B. exemption sticker, (attached), must be visible under the hood so that an emissions inspector can see it when the vehicle is required to be tested for emissions. California requires testing every two years, other states may vary.

7. Service and Maintenance

- a. It is recommended that you service your AEM® Dryflow™ filter every 20,000 miles for optimum performance. Use AEM Dryflow cleaning kit part # 21-110.
- b. Use aluminum polish to clean your polished AEM® intake tube.
- c. Use window cleaner to clean your powder coated AEM® intake tube. **(NOTE: DO NOT USE aluminum polish on powder coated AEM intake tubes).**

For technical inquiries
e-mail us at
sales@aemintakes.com
or
call us at
800.992.3000

AEM Air Intake System Warranty Policy

AEM® warrants that its intake systems will last for the life of your vehicle. AEM will not honor this warranty due to mechanical damage (i.e. improper installation or fitment), damage from misuse, accidents or flying debris. AEM will not warrant its powder coating if the finish has been cleaned with a hydrocarbon-based solvent. The powder coating should only be cleaned with a mild soap and water solution. Proof of purchase of both the vehicle and AEM intake system is required for redemption of a warranty claim.

This warranty is limited to the repair or replacement of the AEM part. In no event shall this warranty exceed the original purchase price of the AEM part nor shall AEM be responsible for special, incidental or consequential damages or cost incurred due to the failure of this product. Warranty claims to AEM must be transportation prepaid and accompanied with dated proof of purchase. This warranty applies only to the original purchaser of product and is nontransferable. Improper use or installation, use for racing, accident, abuse, unauthorized repairs or alterations voids this warranty. AEM disclaims any liability for consequential damages due to breach of any written or implied warranty on all products manufactured by AEM. Warranty returns will only be accepted by AEM when accompanied by a valid Return Merchandise Authorization (RMA) number. Credit for defective products will be issued pending inspection. Product must be received by AEM within 30 days of the date RMA is issued.

If you have a warranty issue, please call (800) 992-3000 and our customer service department will assist you. A proof of purchase is required for all AEM warranty claims.