



Equipped with AEM® Dryflow™ Filter
No Oil Required!

INSTALLATION INSTRUCTIONS

PART NUMBER

22-686C (Gun Metal Grey Finish)

2011	Ford	Mustang	3.7L-V6
2012	Ford	Mustang	3.7L-V6
2013	Ford	Mustang	3.7L-V6
2014	Ford	Mustang	3.7L-V6

Not legal for sale or use on any pollution controlled motor vehicle in California or states adopting California emission procedures. See AEMIntakes.com for CARB status on each part for a specific vehicle.

ITEM NO.	PART NUMBER	DESCRIPTION	QTY.
1	9448	1/2" BNDHOSE CLAMP,2.56"-3.50"	1
2	5-1046	HOSE, ADAPTER 3.00/3.50X2.5	1
3	9456	1/2" BNDHOSE CLAMP,3.15"-4.00"	2
4	2-1512C	TUBE; FORD MUSTANG 3.7L HCA	1
5	082628	VENT; 1/4 NPT TO QUICK DISCONNECT	1
6	28-20431	FORD MUSTANG GT 4.6L V8; 2010	1
7	08032	PLUG; 1/4 NPT, PLASTIC, BLACK	1
8	08047	VENT; STRT, 3/8"HOSE, 1/4"NPT,	1
9	08657	HOSE; HUMP;3.25 ID- 3.5 ID; BLK;	1
10	9452	1/2" BNDHOSE CLAMP,2.90"-3.75"	1

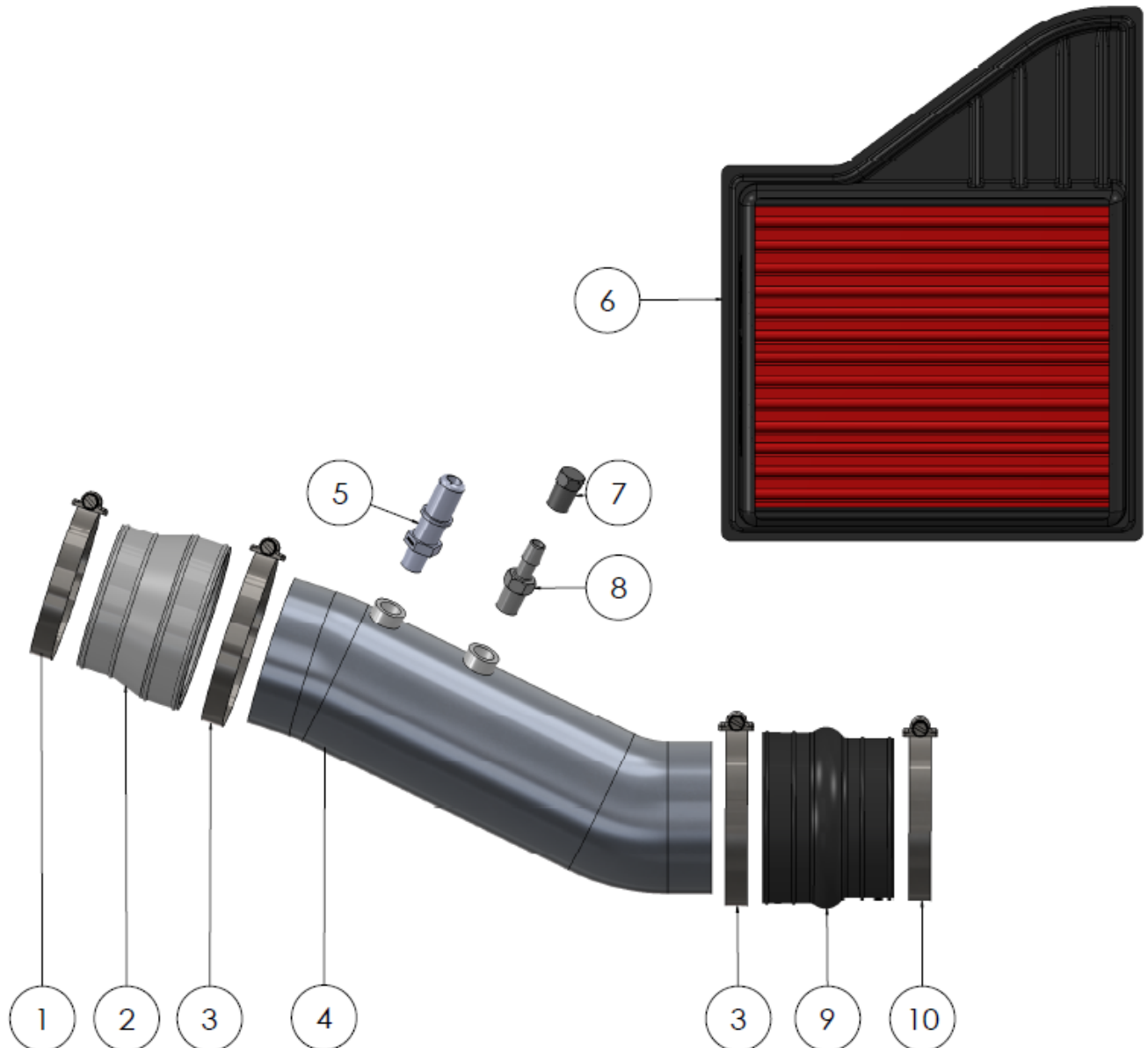

Read and understand these instructions **BEFORE** attempting to install this product. Failure to follow installation instructions and not using the provided hardware may damage the intake tube, throttle body and engine.

1. Preparing Vehicle

- a. Make sure vehicle is parked on level surface.
- b. Set the parking brake.
- c. If engine has run in the past two hours, let it cool down.
- d. Do not discard stock components after removal of the factory system.
- e. Open the air intake kit package and make sure all parts are included.

Tools Needed:

Screw driver
5/8 Wrench

2. Removal of stock system

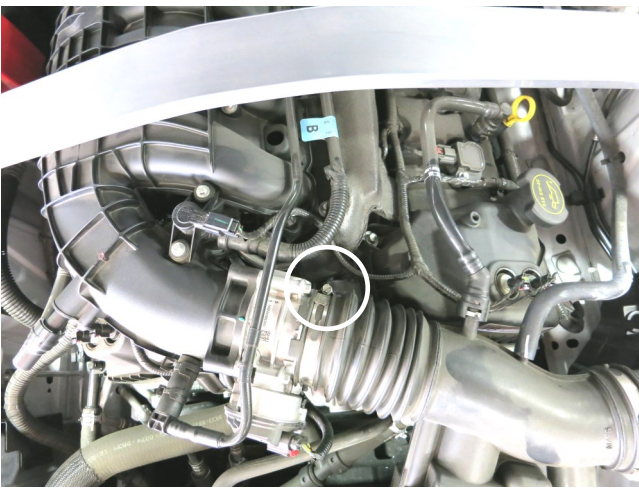

a. Loosen the hose clamp at the throttle body.

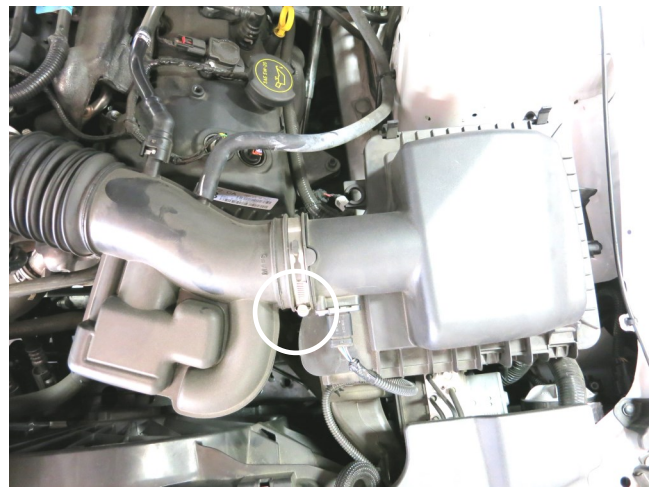

b. Loosen the hose clamp at the air box outlet.

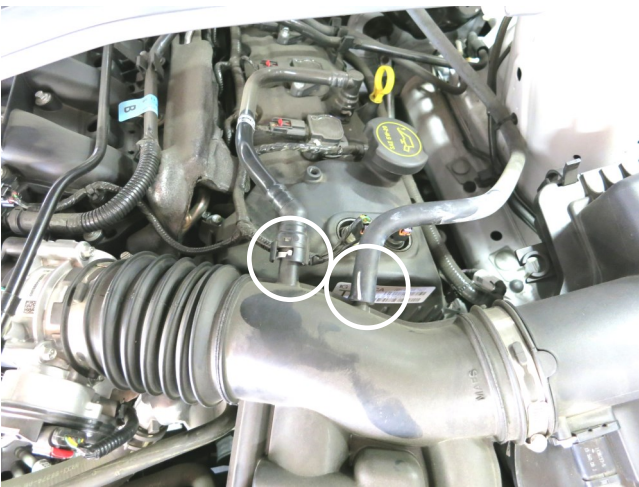

c. Release the pressure on the gray tab and pull the two vent lines from the stock intake tube. Note: Some models may not be equipped with an EVAP vent line.

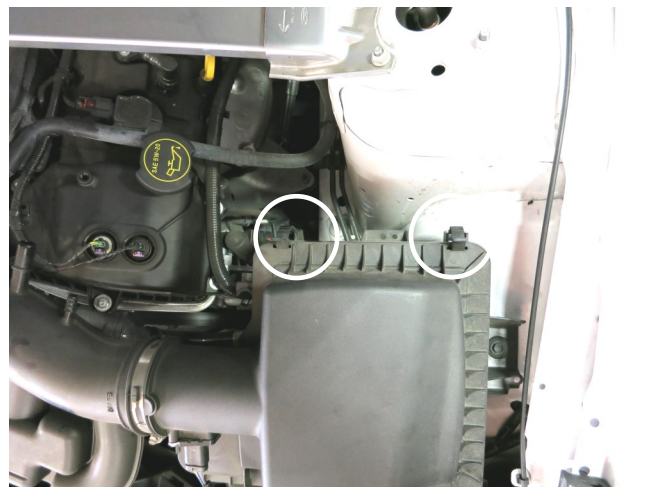

d. Unlatch the two clips securing the upper air box to the lower air box.

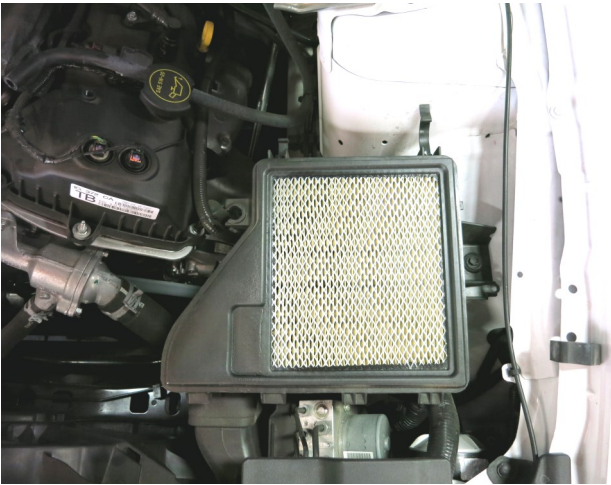

e. Remove the stock air filter from the lower air box.

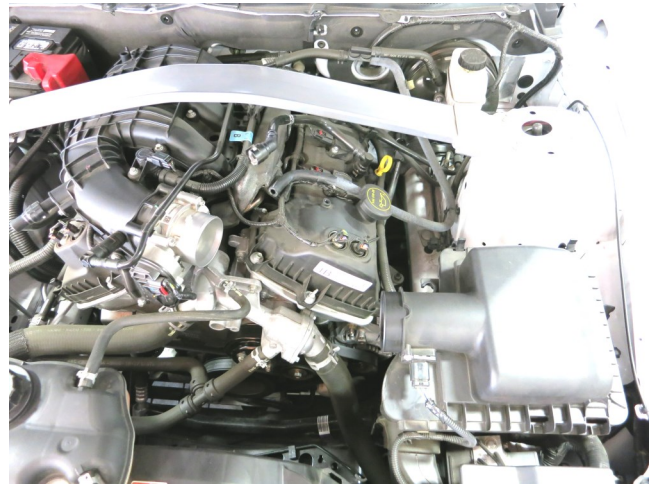

f. Remove the stock intake hose from the vehicle. **Note:** Do not discard any of your stock equipment.

3. Installation of AEM® intake system.

a. When installing the intake system, do not completely tighten the hose clamps or mounting hardware until instructed to do so.



a. Install the AEM filter into the lower air box.



b. Reattach the clips that were removed in step 2d.

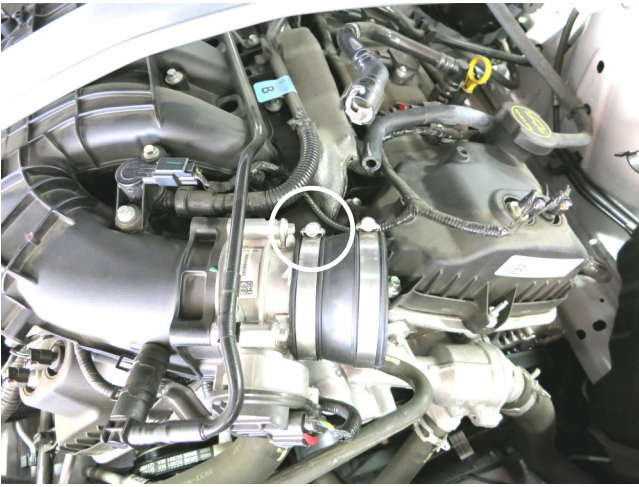

c. Install the coupler (5-1046) and provided hose clamps (9448 & 9456) onto the throttle body. Tighten the hose clamp circled.

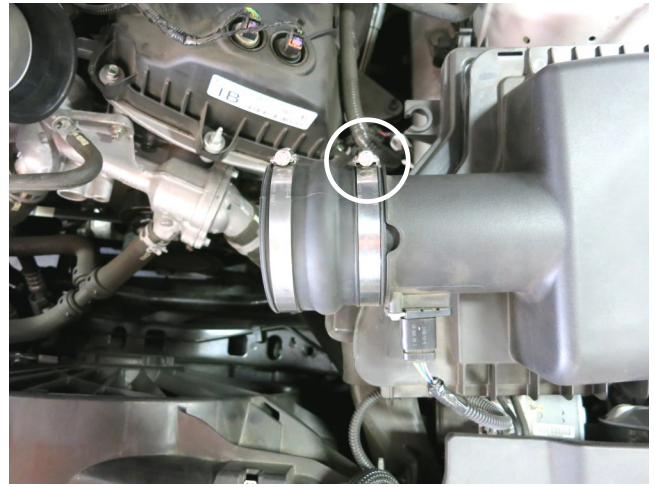

d. Install the coupler (08657) and provided hose clamps (9456 & 9452) onto the air box lid. Tighten the hose clamp circled.



e. Install both vents (082628 & 08047) onto the AEM intake tube as shown. **Note:** On vehicles that are not equipped with an EVAP vent line, install the provided $\frac{1}{4}$ NPT plug (08032) into the AEM intake tube. **Note:** Plastic NPT fittings are easy to cross thread. Install the vent fitting "hand" tight, then turn it two complete turns with a wrench.

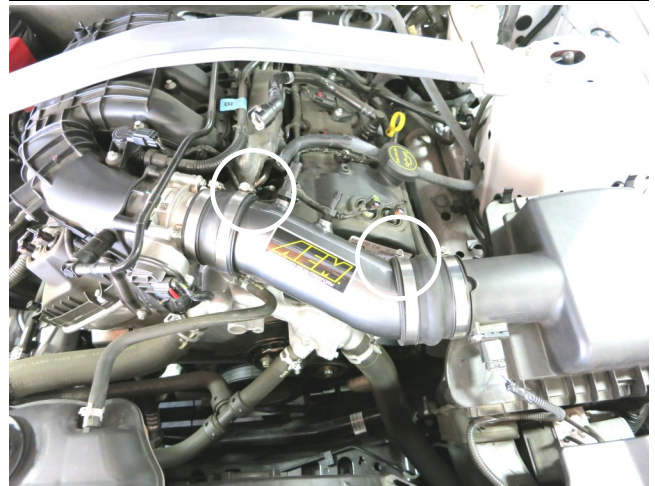

f. Install the completed AEM intake tube assembly into the couplers and secure both hose clamps circled.



g. Reattach both vent lines onto the AEM intake tube that were detached in step 2c.

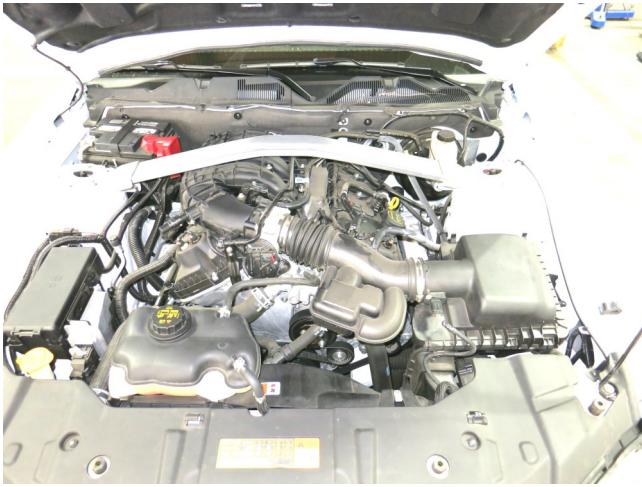

STOCK INTAKE INSTALLED



AEM INTAKE INSTALLED

4. Reassemble Vehicle

- a. Position the inlet pipes for the best fitment. Be sure that the pipes or any other components do not contact any part of the vehicle.
- b. Check for proper hood clearance. Re-adjust pipes if necessary and re-tighten them.
- c. Inspect the engine bay for any loose tools and check that all fasteners that were moved or removed are properly tightened.
- d. Reconnect negative battery terminal and start engine. Let the vehicle idle for 3 minutes. Perform a final inspection before driving the vehicle.

5. Service and Maintenance

- a. AEM Induction Systems requires cleaning the intake system's air filter element every 100,000 miles. When used in dusty or off-road environments, our filters will require cleaning more often. We recommend that you visually inspect your filter once every 25,000 miles to determine if the screen is still visible. When the screen is no longer visible some place on the filter element, it is time to clean it. To clean, purchase our Synthetic air filter cleaner, part number 1-1000 and follow the easy instructions.
- b. Use window cleaner to clean your powder coated AEM[®] intake tube.

NOTE: DO NOT USE aluminum polish on powder coated AEM[®] intake tubes.

For technical inquiries
e-mail us at
sales@aemintakes.com
or
call us at
800.992.3000

AEM Air Intake System Warranty Policy

AEM® warrants that its intake systems will last for the life of your vehicle. AEM® will not honor this warranty due to mechanical damage (i.e. improper installation or fitment), damage from misuse, accidents or flying debris. AEM® will not warrant its powder coating if the finish has been cleaned with a hydrocarbon-based solvent. The powder coating should only be cleaned with a mild soap and water solution. Proof of purchase of both the vehicle and AEM® intake system is required for redemption of a warranty claim.

This warranty is limited to the repair or replacement of the AEM® part. In no event shall this warranty exceed the original purchase price of the AEM® part nor shall AEM® be responsible for special, incidental or consequential damages or cost incurred due to the failure of this product. Warranty claims to AEM® must be transportation prepaid and accompanied with dated proof of purchase. This warranty applies only to the original purchaser of product and is nontransferable. Improper use or installation, use for racing, accident, abuse, unauthorized repairs or alterations voids this warranty. AEM® disclaims any liability for consequential damages due to breach of any written or implied warranty on all products manufactured by AEM®. Warranty returns will only be accepted by AEM® when accompanied by a valid Return Merchandise Authorization (RMA) number. Credit for defective products will be issued pending inspection. Product must be received by AEM® within 30 days of the date RMA is issued.

If you have a warranty issue, please call (800) 992-3000 and our customer service department will assist you. A proof of purchase is required for all AEM® warranty claims.

Not legal for sale or use on any pollution controlled motor vehicle in California or states adopting California emission procedures. See AEMIntakes.com for CARB status on each part for a specific vehicle.