



DON'T FORGET
These instructions can be found in
color and expandable at QA1.net

Technical Support Line: (952) 985-5675 Email: sales@QA1.net

INSTALLATION INSTRUCTIONS

QA1 P/N 52922, 52917, 52918, 52965, 52967

Drag Race Upper Control Arms

TOOLS AND SUPPLIES REQUIRED

- Floor Jack
- Jack Stands
- Wrench Set
- Ratchet & Socket Set
- Spring Compressor
- Ball Joint Separator
- *QA1 Ball Joint Tool Kit p/n 1891-106

PRE-INSTALLATION NOTES:

QA1 does not recommend driving the vehicle until it has been properly aligned due to major changes in suspension geometry that will affect the handling characteristics of the vehicle. *A front-end alignment should be performed by a qualified alignment shop after installation.*

Drag Race upper control arms come with low friction composite bushings and QA1 Ultimate (low friction) Ball Joints; please refer to the ball joint instructions on page 2 for setting the initial preload. Preload is set from the factory, but the ball joint preload should be checked before installing these **Drag Race upper control arms** and every race season.

Drag Race upper control arms also come with an adjustable droop stop for adjusting the front suspension travel. (**Figure 1**)

Disassembly With Factory Springs

1. Raise and support the vehicle by the frame with jack stands on a stable surface and remove the front wheels.
2. Remove the cotter pin and loosen the ball joint castle nut on the upper ball joint. **Do not remove the nut at this time.**
3. With the castle nut still threaded onto the stud, separate the upper ball joint from the spindle using a ball joint separator.
4. Support the lower control arm with a jack to take the pressure off the droop stop and to contain the spring pressure. (**Figure 2**)
5. Remove the upper ball joint nut.
6. Note the amount and position of shims installed in the cross shaft of the upper control arm. The amount and position of these shims will be used on the new control arms.
7. Loosen the upper control arm nuts and remove the arm.

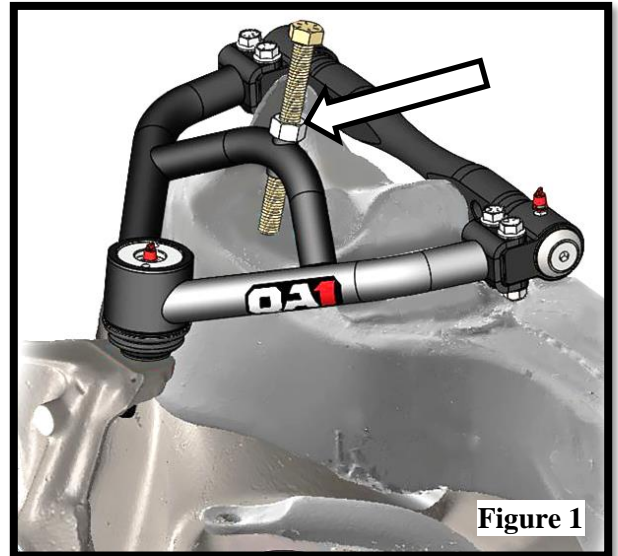

Figure 1

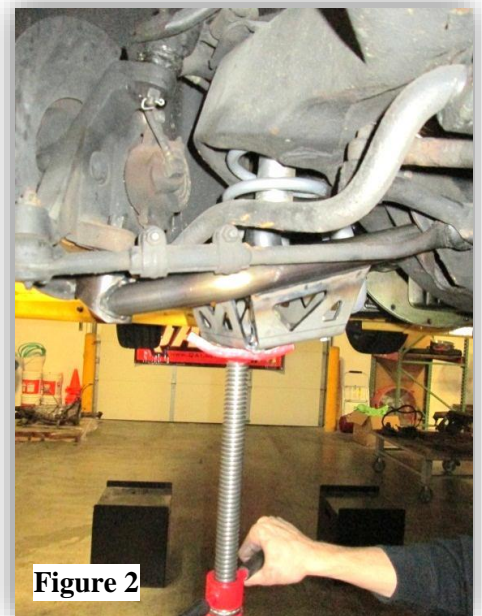

Figure 2

Disassembly When Using Front Coil-overs

1. Raise and support the vehicle by the frame with jack stands on a stable surface and remove the front wheels.
2. Remove the sway bar end links. (if equipped)
3. Remove the brake calipers and secure them out of the way. Do not let the calipers hang by the brake lines as this may damage the lines.
4. Remove the cotter pins and loosen the ball joint castle nuts on the upper and lower ball joints. **Do not remove the nuts at this time.**
5. With the castle nuts still threaded onto the studs, separate the upper and lower ball joints from the spindle using a ball joint separator.
6. Support the lower control arm with a jack to take pressure off the droop stop and to contain the spring pressure. **(Figure 2)**
7. Remove the upper ball joint nut.
8. Remove ABS wire from upper control arm. (if equipped)
9. Note the position of the shims on the cross shaft of the upper control arm. **(Figure 3)**
10. Remove the nuts on the cross-shaft and remove the upper control arm from the car.

NOTES:

The studs retaining the cross-shaft are knurled. QA1 control arms do not include new knurled studs because it is not recommended to remove the studs unless they are damaged. If a damaged stud needs to be removed it should be pressed or knocked out of the mount. Do not turn the studs to remove.

'64-'72 GM A-body cars will need the factory bump stop removed from the chassis before install.

INSTALLATION NOTE:

These control arms come with 7/16" and 1/2" washers for installation between the cross-shaft and retaining nut. Some applications use 7/16" factory hardware and some will use 1/2" factory hardware. Determine the correct washer size for your application.

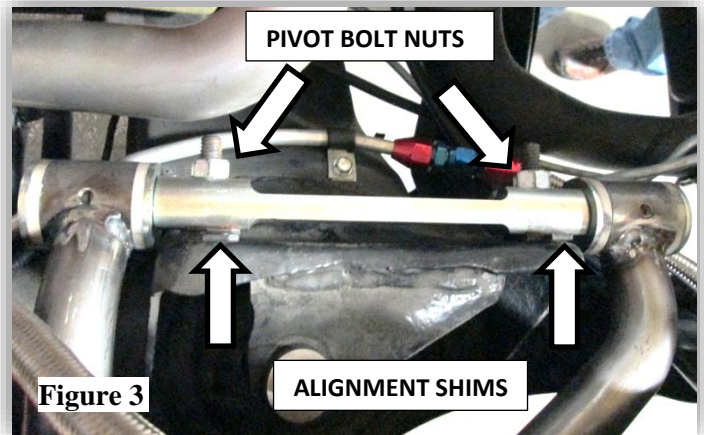

Figure 3

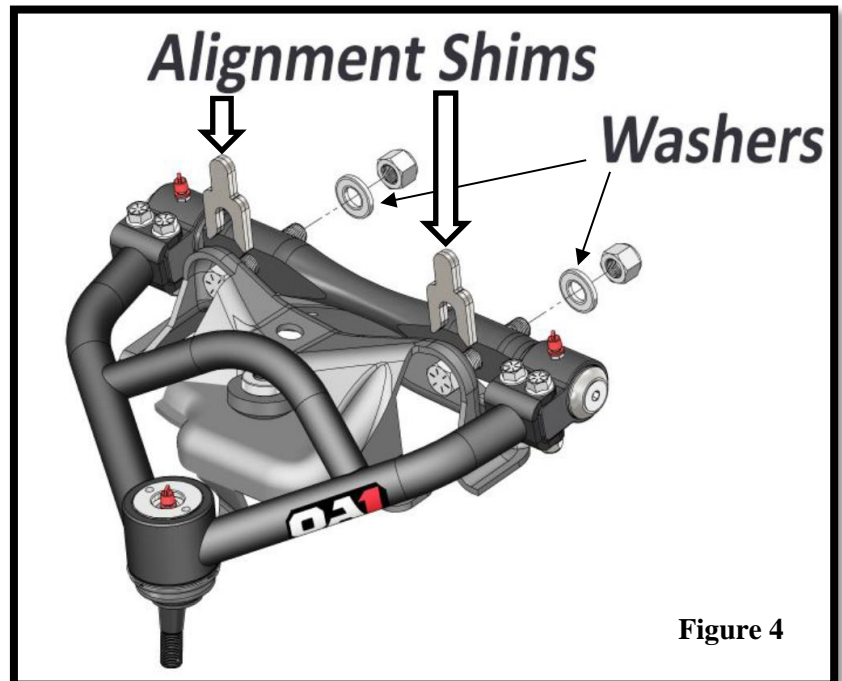

Figure 4

INSTALLATION:

1. Install the provided washers between the aluminum cross-shaft and the factory hardware. The smooth side of the washer should face the cross-shaft. Failure to install a washer between the nut and the cross-shaft will damage the arm. **(Figure 4)**
2. Install QA1 upper control arms onto the mounting studs with all of the shims originally removed in their original positions. **(Figure 4)**

3. Tighten the factory hardware to 40 lb. ft. If the mounting studs have been removed, it may be necessary to hold the head of the bolt to tighten the cross-shaft nuts. **Do not turn the bolt to tighten the cross-shaft nuts or it will strip the knurling.**
4. Connect the upper ball joint to the spindle and tighten the ball joint castle nut with included washer. Torque to 55 lb. ft. Continue tightening the nut to line up the first available cotter pin hole.
5. Install a new cotter pin to secure.
6. Remove the jack from the lower control arm.
7. Thread the 1/2" x 5" bolt with jam nut into the control arm from the top. **(Figure 5)**
8. Adjust the droop stop bolt to the desired height and snug the jam nut against the control arm. Check inner fender clearance at desired height.
9. Lightly grease control arm and ball joint zerk fittings using a quality lithium bearing grease.
10. Reinstall the wheels.

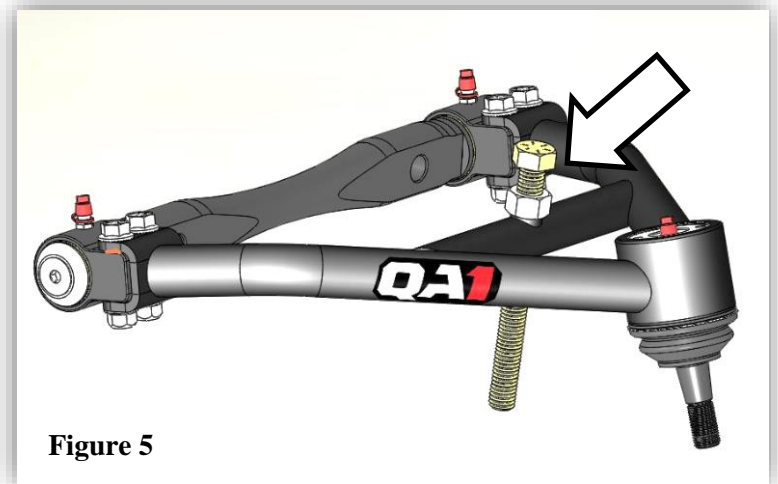

Figure 5

A PROFESSIONAL ALIGNMENT SHOULD BE PERFORMED BEFORE DRIVING THE VEHICLE

(Recommended alignment specs on reverse)

Maintenance of QA1 Ultimate Ball Joints

Grease the ball joint using high quality NLGI #2 GC-LB Lithium based grease and check preload on a regular basis. Check and set ball joint preload at least annually or every 3,000 miles, whichever comes first.

NOTE: Preload on the ball stud can be set with the ball joint attached to the control arm if the spring is unloaded and the ball joint taper is free from the spindle.

1. Using the QA1 spanner socket from Ball Joint Tool Kit (p/n 1891-106) loosen the lock nut by turning counter-clockwise.
2. Using the QA1 hex key, torque the torque nut to 25-30 in. lbs. and then back off 90°.
3. Using the QA1 hex key, a 1/2" open-ended wrench or socket, and the QA1 spanner wrench, tighten the lock nut while holding the torque nut, locking them together to 25 ft. lbs.
4. Re-check the lash on the ball stud and adjust as needed. The ball stud should not have any axial lash.
5. Using a grease gun, lubricate and rotate the ball stud by hand until the grease is visible on the bottom of the ball. If the ball joint is on the car, move the suspension up and down to get the same effect. Note: Excessive grease may result in hydraulic lock. If this occurs, move the ball stud until pressure is relieved and the ball stud freely rotates.

Alignment Information

QA1 upper and lower control arms are designed to add positive caster and negative camber. It is a good idea to make the alignment shop aware of this, as the alignment shop will only try to align the vehicle to factory specs. These alignment specifications are for vehicles equipped with both QA1 upper and lower control arms. Vehicles with other configurations may not be able to achieve these alignment specifications.

Recommended Alignment Specifications for Street Driving

1964-1972 A-Body	Camber:	0° to -1°
1967-1981 Camaro and Firebird	Caster:	3° to 5°
1968-1974 Nova, X-Body	Toe:	.1° to .3° toe in
1973-1977 A-Body		
1975-1979 Nova, X-Body		
1978-1988 A-Body and G-Body	Camber:	0° to -1°
1982-2003 S Series	Caster:	4° to 7°
	Toe:	.1° to .3° toe in
1982-1992 Camaro and Firebird	Camber	0° to -1°
	Caster	4° to 6°
	Toe:	.1° to .3° toe in

NOTE ON ALIGNMENT SPECS:

Alignment specifications will vary based on the vehicles use and the above are based on street vehicles. Autocross and track prepped cars will typically use up to 2 degrees of negative camber, max out the available caster, and use 1/8" toe-out alignment spec. Drag racing will typically use similar specs to a street car while maxing out the positive caster with varying toe-in settings to increase straight line stability. Consult with your alignment professional for the specifications that will work best for your application.



Technical Support Line: (952) 985-5675 Email: sales@QA1.net

READ ALL INSTRUCTIONS CAREFULLY AND THOROUGHLY PRIOR TO STARTING INSTALLATION. PRODUCTS THAT HAVE BEEN INSTALLED ARE NOT ELIGIBLE FOR RETURN. USE THE PROPER JACKING LOCATIONS. DEATH OR SERIOUS INJURY CAN RESULT IF INSTRUCTIONS ARE NOT CORRECTLY FOLLOWED. A GOOD CHASSIS MANUAL, AVAILABLE AT YOUR LOCAL PARTS STORE, MAY ALSO AID IN YOUR INSTALLATION.

• DISCLAIMER / WARRANTY •

QA1 WARRANTS THAT THE PRODUCTS WILL BE FREE FROM DEFECTS IN MATERIAL AND WORKMANSHIP FOR ONE YEAR FROM DATE OF SALE TO THE ORIGINAL PURCHASER. QA1 MAKES NO OTHER WARRANTY OF ANY KIND, EXPRESS OR IMPLIED. QA1 SHALL HAVE NO OBLIGATION UNDER THE FOREGOING WARRANTY WHERE THE DEFECT IS THE RESULT OF IMPROPER OR ABNORMAL USE, YOUR NEGLIGENCE, VEHICLE ACCIDENT, IMPROPER OR INCORRECT INSTALLATION OR MAINTENANCE, NOR WHEN THE PRODUCT HAS BEEN REPAIRED OR ALTERED IN ANY WAY. QA1'S LIABILITY IN THE CASE OF DEFECTIVE PRODUCTS SUBJECT TO THE FOREGOING WARRANTY SHALL BE LIMITED TO THE REPAIR OR REPLACEMENT, AT QA1'S OPTION, OF THE DEFECTIVE PRODUCTS.

THE USER UNDERSTANDS AND RECOGNIZES THAT RACING PARTS, SPECIALIZED STREET ROD EQUIPMENT, AND ALL PARTS AND SERVICES SOLD BY QA1 ARE EXPOSED TO MANY AND VARIED CONDITIONS DUE TO THE MANNER IN WHICH THEY ARE INSTALLED AND USED. QA1 SHALL BEAR NO LIABILITY FOR ANY LOSS, DAMAGE OR INJURY, EITHER TO A PERSON OR TO PROPERTY, RESULTING FROM THE INSTALLATION, DIRECT OR INDIRECT USE OF ANY QA1 PRODUCTS OR INABILITY BY THE BUYER TO DETERMINE PROPER USE OR APPLICATION OF QA1 PRODUCTS. WITH THE EXCEPTION OF THE LIMITED LIABILITY WARRANTY SET FORTH ABOVE, QA1 SHALL NOT BE LIABLE FOR ANY CLAIMS, DEMANDS, INJURIES, DAMAGES, ACTIONS, OR CAUSES OF ACTION WHATSOEVER TO BUYER ARISING OUT OF OR CONNECTED WITH THE USE OF ANY QA1 PRODUCTS. MOTORSPORTS ARE DANGEROUS; AS SUCH, NO WARRANTY OR REPRESENTATION IS MADE AS TO THE PRODUCT'S ABILITY TO PROTECT THE USER FROM INJURY OR DEATH. THE USER ASSUMES THAT RISK!