



Installation Instructions for:  
**SYSTEM #17119**  
1964-1972 GM "A" Body



12/4/14

**Installation:**

- 1) Raise the vehicle up on a hoist or rack to working height. If you do not have access to a hoist or rack raise the vehicle and support securely with jack stands.
- 2) On the frame of the vehicle, slightly forward of the rear axle, there are a set of two mounting holes on each side of the vehicle (use the two inner holes) which will be used to fasten the rear muffler hanger mounts. Use these stock locations to secure hanger **#298HA** (64-67) or **290HA** (68-72) on the left side and hanger **#297HA** (64-67) or **289HA** (68-72) on the right side. Use the 5/16" x 1" bolts and nuts provided. See Diagram #1.
- 3) Slide the two rubber isolators **#HA168** onto the two hanger mounts that were installed in the previous step. Slide the two clamp hangers **#489HA** into bottom holes of the rubber isolators. The hanger rod should be inserted from the outside. Place the mufflers up into position with stands and place the outlets of the mufflers into the clamp hangers. Tighten enough to hold in place but still allow for adjustment.
- 4) Slide a clamp over each muffler inlet. Place H-pipe assembly **#16008** in its approximate position underneath the vehicle and connect the back of the H-pipe into the muffler inlets and support with a stand. Tighten clamps just enough to hold but still allow for adjustment.
- 5) Place the right tailpipe **#16155** in position over the axle on the right side of the vehicle. Place the left tailpipe **#16154** in position over the axle on the left side of the vehicle. When installing tailpipes, the rear of the vehicle must be supported by the frame with jack stands, allowing the axle to hang from the suspension. *(Note: The car should be supported by the axle after the tailpipes are in place.)*
- 6) Bolt the tailpipe hangers **#HA572** in the stock location on the rear quarter frame rails using the 5/16" x 3/4" thread cutting bolts, nuts and washers provided. Use the lower of the two factory holes.
- 7) Place hanger assembly **#487HA** over the rear of the right tailpipe and connect to the **#HA572** hanger installed in the step above. Tighten the clamps enough to hold in place. Repeat this step on the left side with hanger **#488HA**.
- 8) Insert the tailpipes into the muffler outlets and adjust the mufflers and tailpipes into their approximate final position.

9) The front connector pipes are long enough to allow for many different header combinations, therefore, it is necessary to determine the proper length of the inlet connector pipes. Once the proper length is determined, trim the front connector pipes. To accommodate for width, cut the end of **#16157** where it enters into the H-pipe.

10) Once the pipes are cut to the proper length, raise them into position and connect them to the H-pipe and header collectors or manifold down pipes using a standard Header Flange or Flowmaster Venturi Cone.

11) Adjust the position of the muffler and all pipes to provide proper fit and adequate clearance for suspension travel. Maintain a minimum of 3/4" clearance between Flowmaster system and the drivetrain and chassis components.

12) Tighten all clamped connections down securely. Install the four 7/16" push-on hanger keepers on the round stock sticking through the rubber muffler hangers.

13) For a cleaner appearance and more secure installation, we highly recommend welding all slip-fit connections. If you live in a geographical area that has harsh winters or sees a great deal of precipitation, the use of temperature paint over the welded areas can help to prevent surface rust and premature corrosion.

### PACKING LIST

<u>Qty</u>	<u>Description</u>	<u>Part #</u>
2	Muffler	952548
2	Connector Pipes, (R/L)	16157
1	H-Pipe Assembly	16008
1	Tailpipe, Right	16155
1	Tailpipe, Left	16154
2	Straight Exit Pipe	16156A
2	Bent Exit Pipe	16156B
1	Parts Kit	PK119
4	2 1/2" Clamps	MC250S
1	Tailpipe Hanger (R)	487HA
1	Tailpipe Hanger (L)	488HA
1	64-67 Hanger Mount (L)	298HA
1	64-67 Hanger Mount (R)	297HA
1	68-72 Hanger Mount (L)	290HA
1	68-72 Hanger Mount (R)	289HA
2	Clamp Hanger Assy	489HA
2	Rubber Isolator	HA168
4	Push-On Hanger Keeper	HW502
2	Tailpipe Hanger(R/L)	HA572
2	5/16" x 1" Bolt	
2	5/16" x 3/4" Cutting Bolt	
2	5/16" Nut	
4	5/16" Lock Washer	
2	5/16" Flat Washer	

DIAGRAM 1

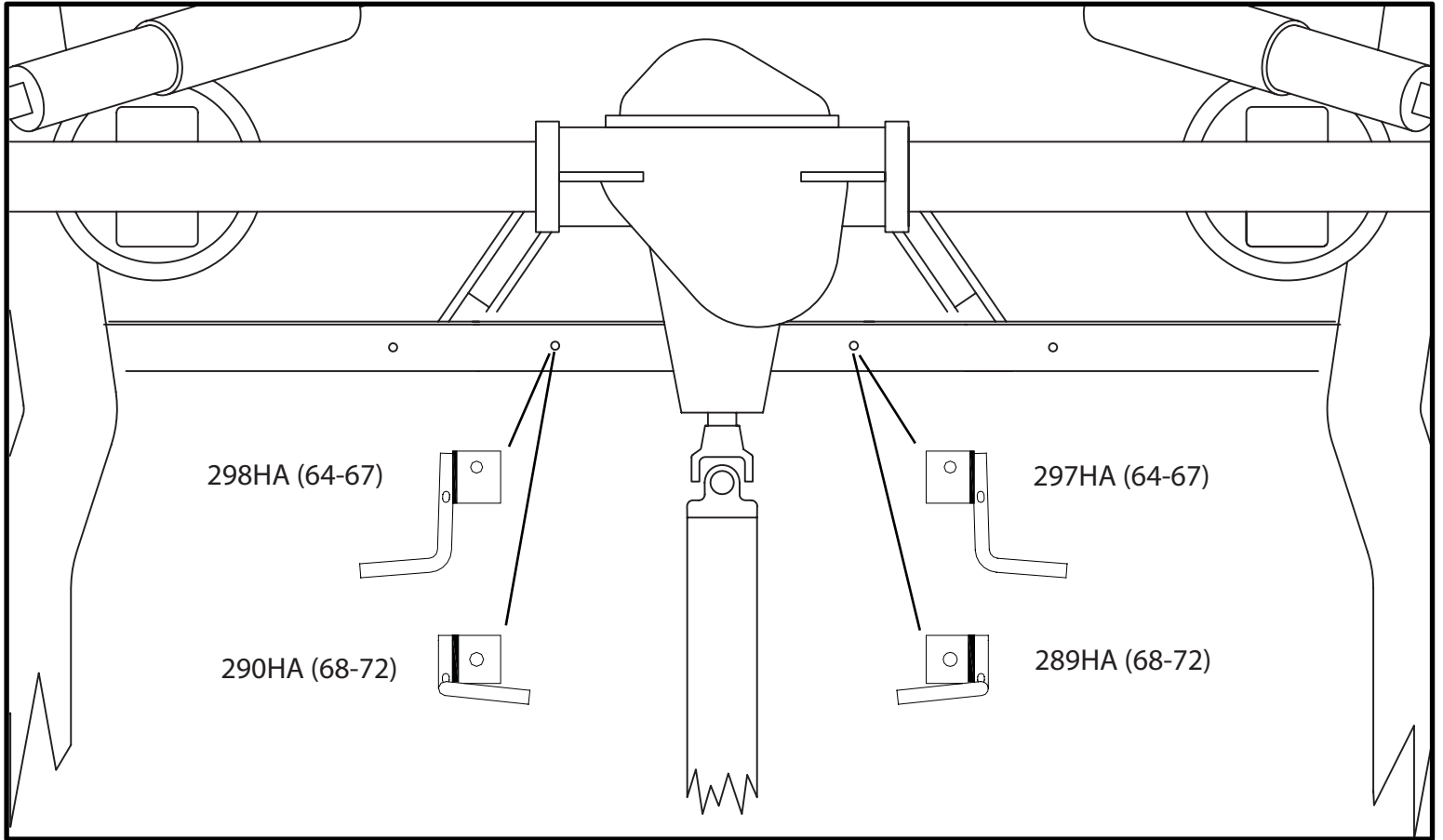



Installation diagram for:  
**SYSTEM #17119**  
1964-1972 GM "A" BODY

